

Model Name: 945GM-DS2

Revision 2.0

SHEET TITLE

01	COVER SHEET
02	BLOCK DIAGRAM
03	BOM & PCB MODIFY HISTORY
04	P4 LGA775 A
05	P4 LGA775 B,D
06	P4 LGA775 C
07	P4 LGA775 E,F,G,H
08	945G HOST
09	945G DDRII
10	945G PCI E, DMI
11	945G VGA
12	945G GND
13	945G PWR
14	PCI EXPRESS*16 SLOT
15	DDRII CHANNEL A
16	DDRII CHANNEL B
17	DDRII TERMINATION
18	ICH7 PCI, USB, DMI, LAN
19	ICH7 IDE, GPIO, SATA, CTRL
20	ICH7 VCC, GND
21	CK410M CLOCK.
22	PCI SLOT 1,2,PCIE*1
23	IDE/FLOPPY
24	ITE 8718 GB/KX
25	COM LPT
26	CI, HWM, KB/MS, BIOS
27	ALC888

SHEET TITLE

28	REAR AUDIO JACK
29	DISCRETE POWER
30	VCORE PWM ISL6312
31	ATX, OTHERS POWER
32	FRONT PANEL
33	TI TSB43AB23 1394
34	REALTEK RTL8111B

Gigabyte Technology

Title		
Cover Sheet		
Size	Document Number	Rev
Custom	945GM-DS2	2.0
Date:	Wednesday, November 08, 2006	Sheet 1 of 34

BLOCK DIAGRAM

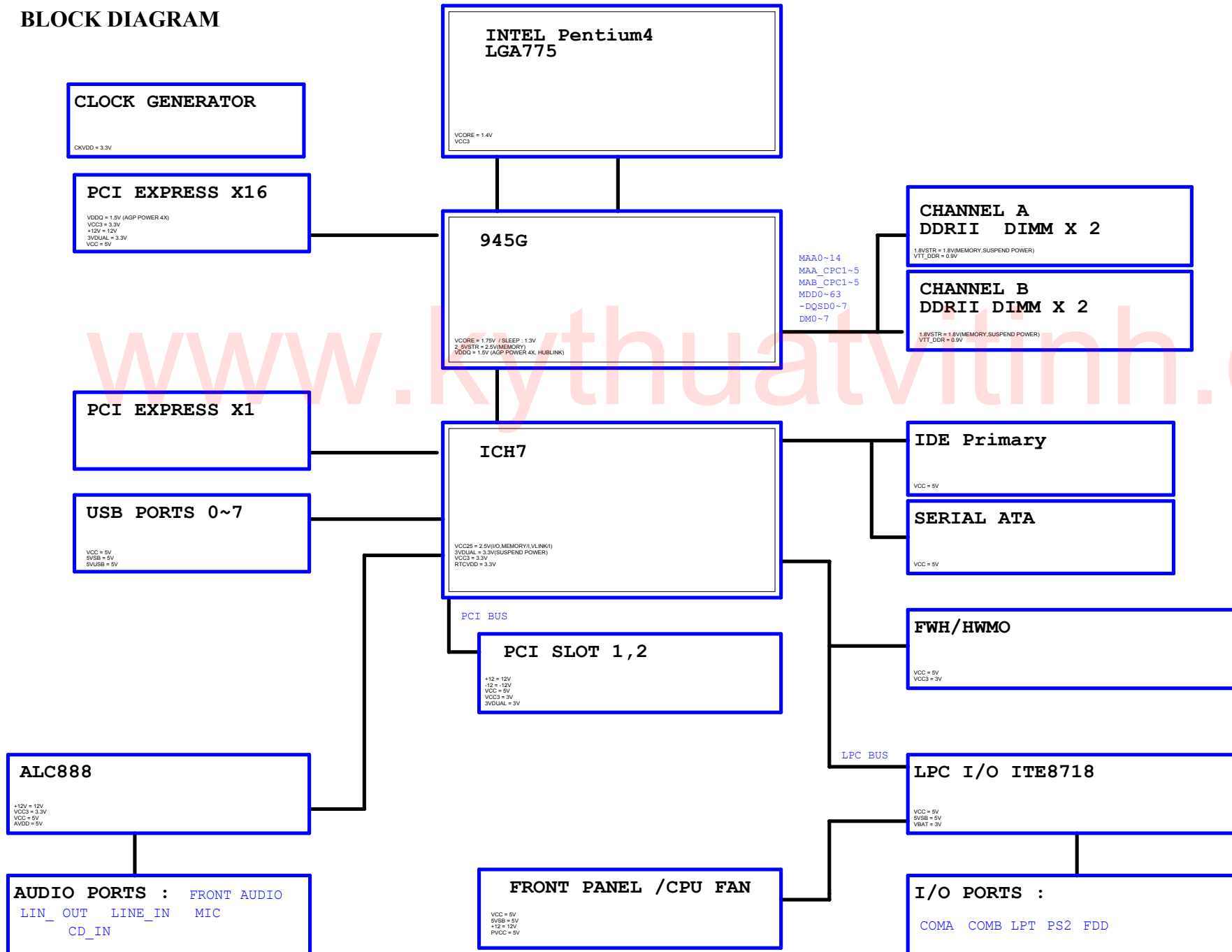

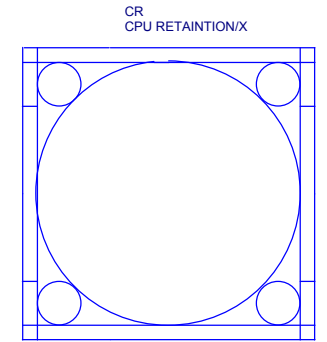
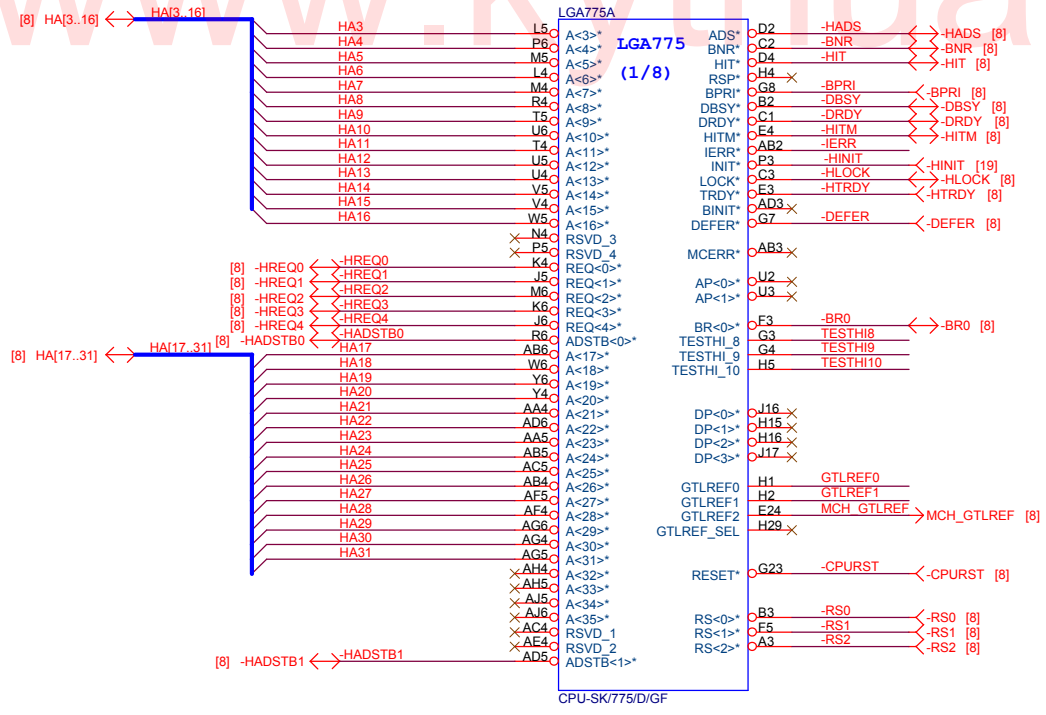
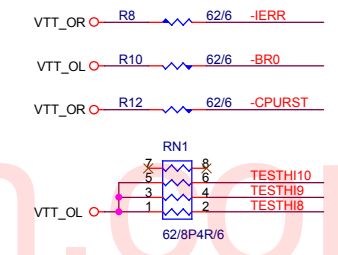
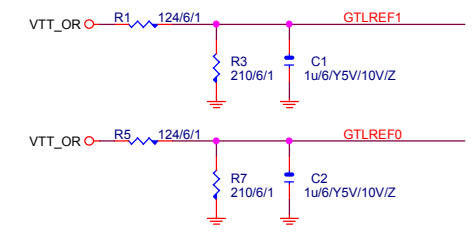
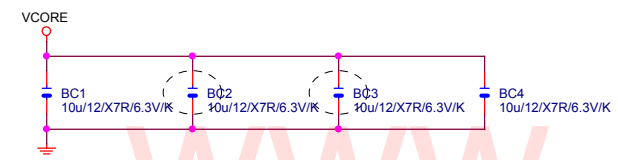
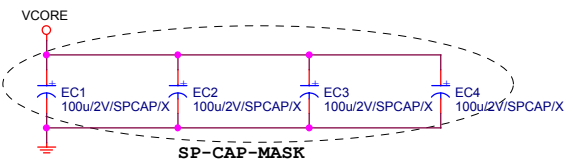
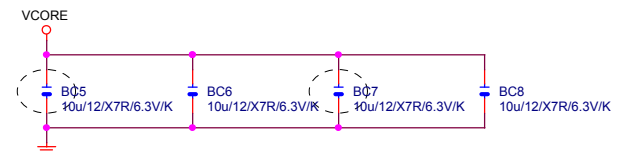

Gigabyte Technology		
Title		
P4_LGA775-A		
Size B	Document Number	Rev
	945GM-DS2	2.0
Date:	Wednesday, November 08, 2006	Sheet 4 of 34

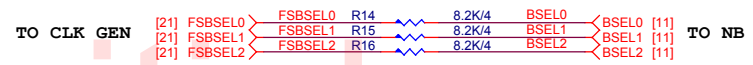
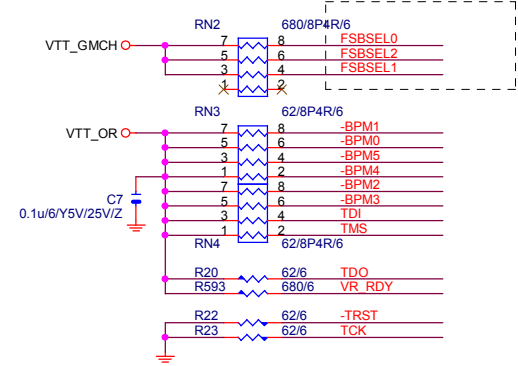
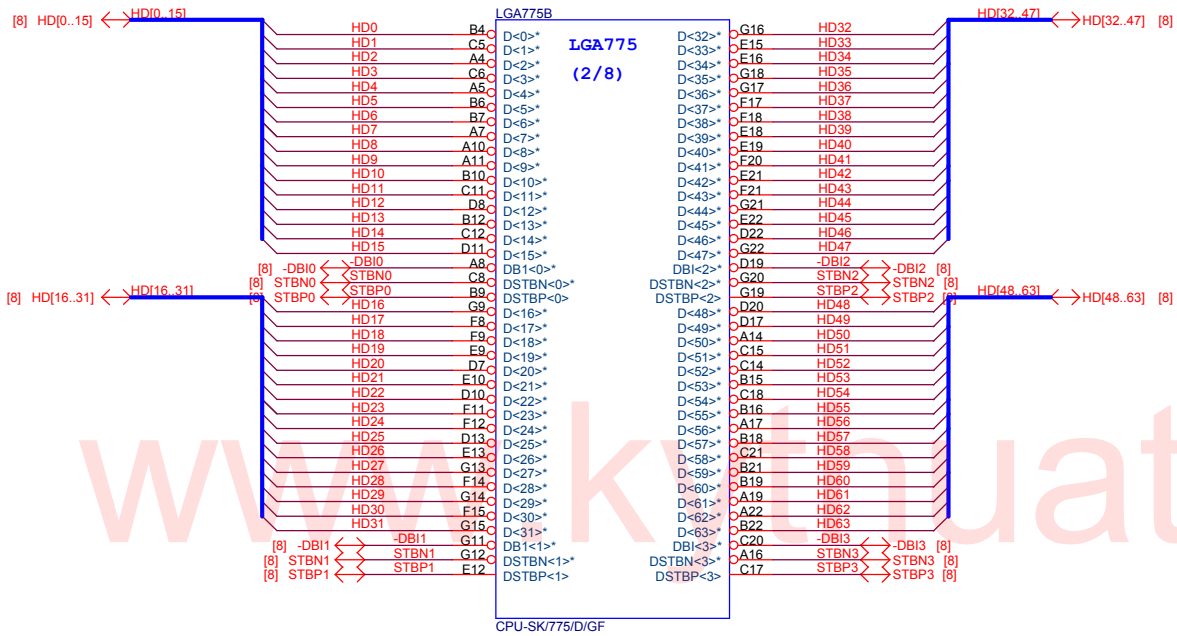

CPU

NA	FSB	FSA	Clock
FSBSEL3	FSBSEL1	FSBSEL0	100MHz
1	0	1	100MHz
0	0	1	133MHz
0	1	1	166MHz
0	1	0	200MHz
0	0	0	266MHz

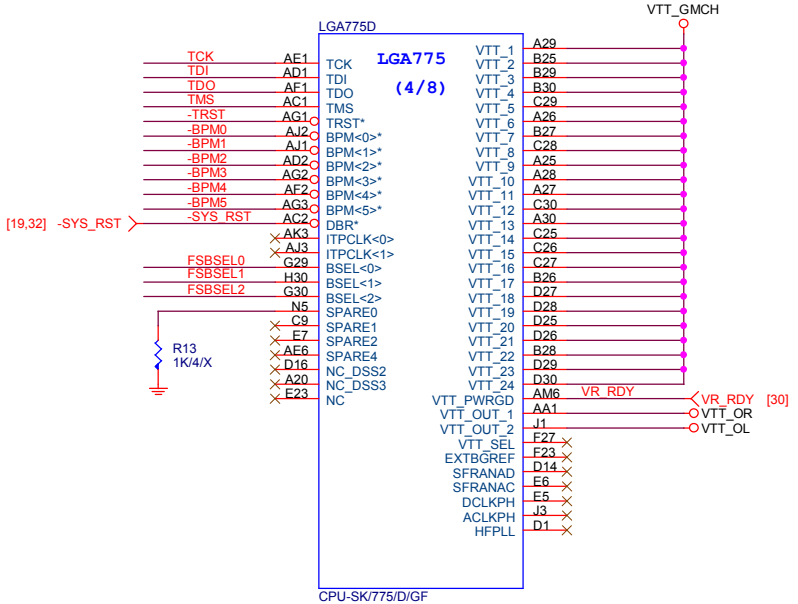

Gigabyte Technology

Title: **P4_LGA775-B,D**

Size B	Document Number	Rev
	945GM-DS2	2.0

Date: Wednesday, November 08, 2006 Sheet 5 of 34

Note:
VCCA & VCOREPLL
define doesn't same as
old P4 design kit

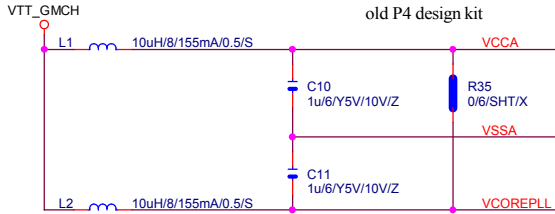

Trace width doesn't
less than 12 Mil

As close as possible to
CPU socket

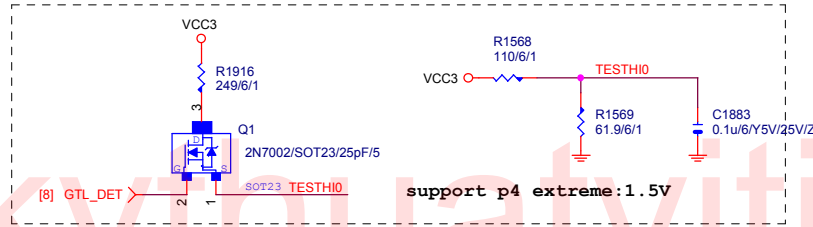

Place outside of CPU socket

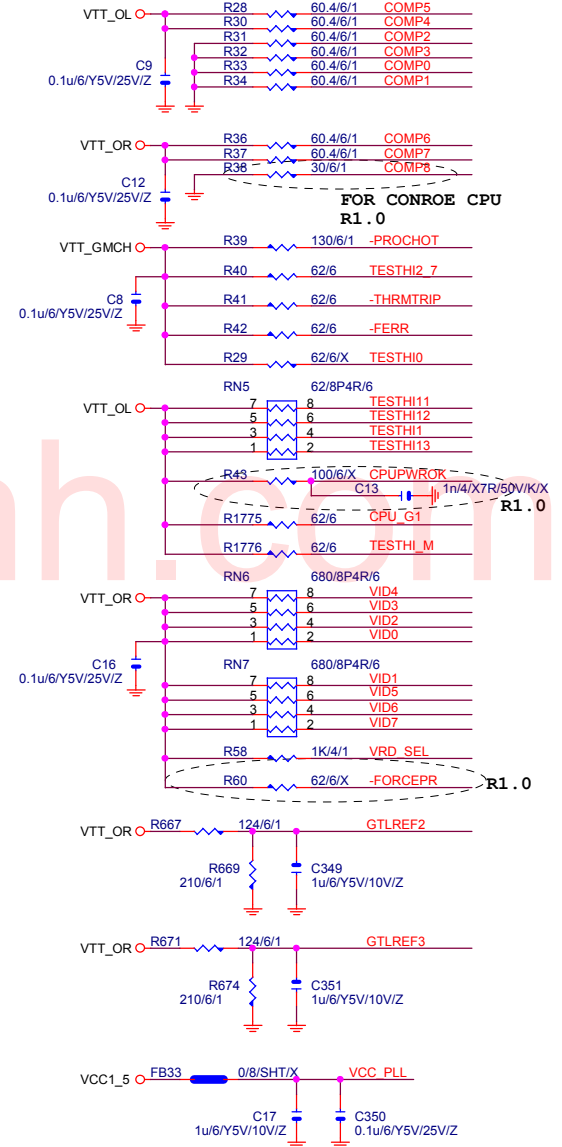

FOR CONROE CPU
R1.0

R1.0

R1.0

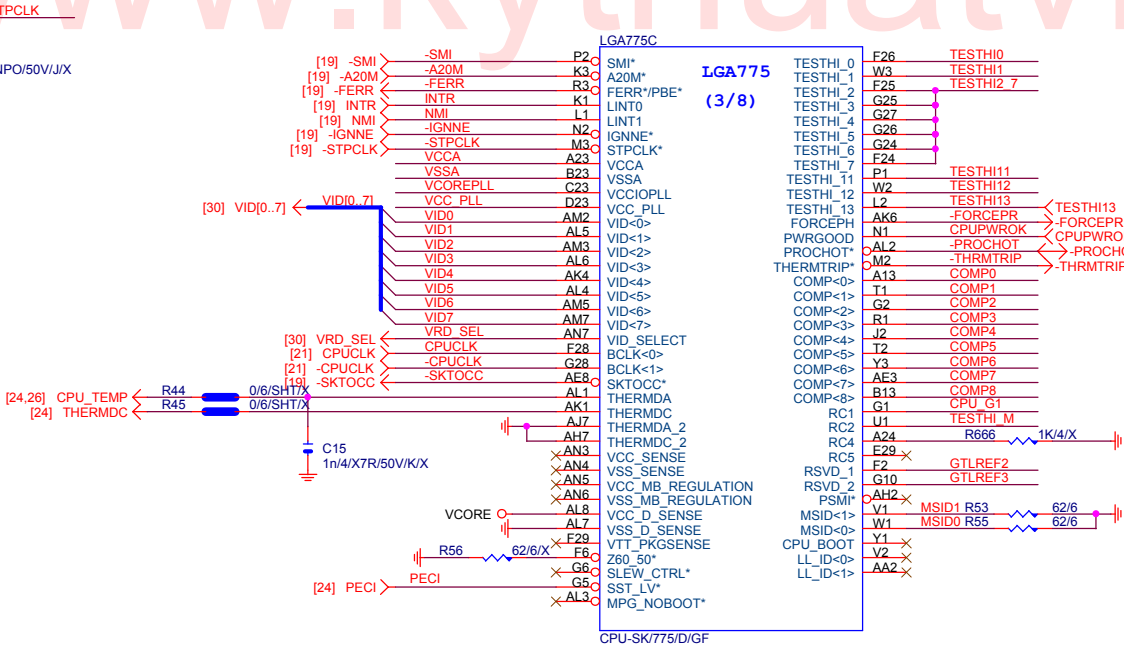

Gigabyte Technology		
Title P4_LGA775-C		
Size B	Document Number 945GM-DS2	Rev 2.0
Date:	Wednesday, November 08, 2006	Sheet 6 of 34

PECI: Platform Environment Control Interface

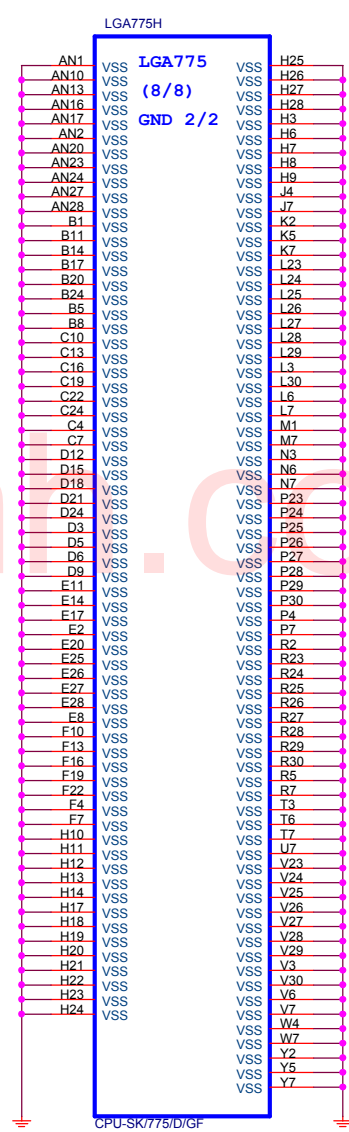
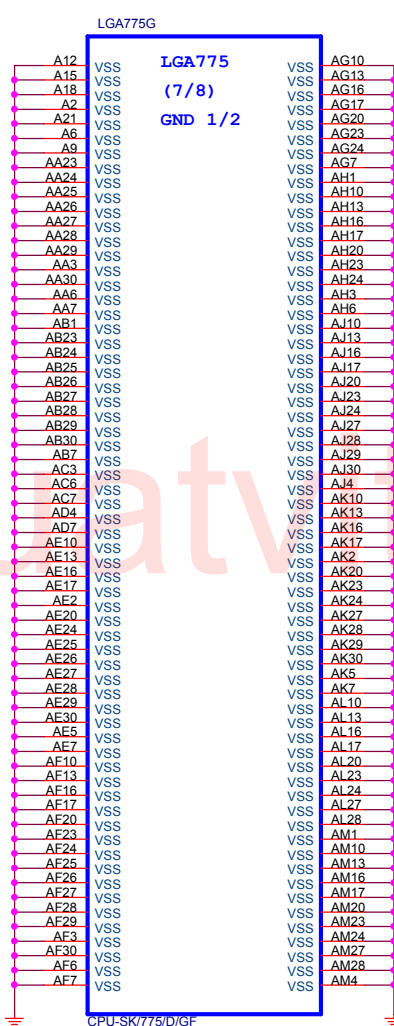
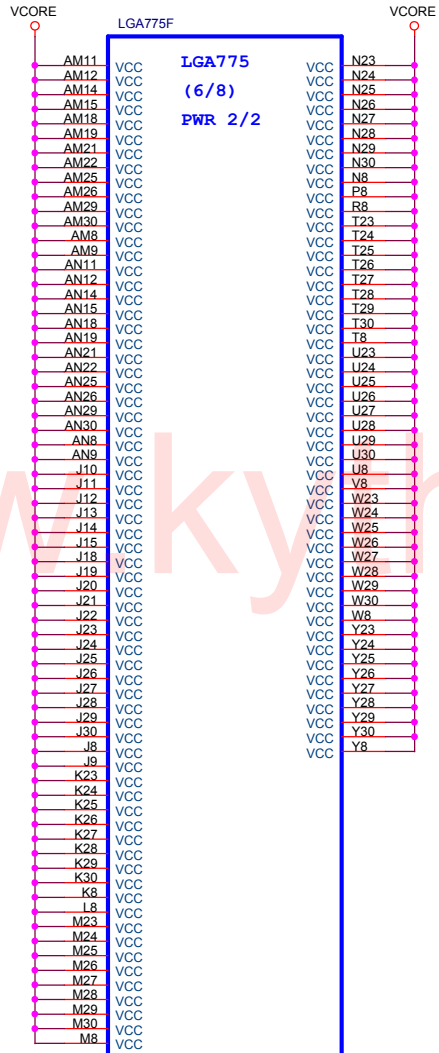
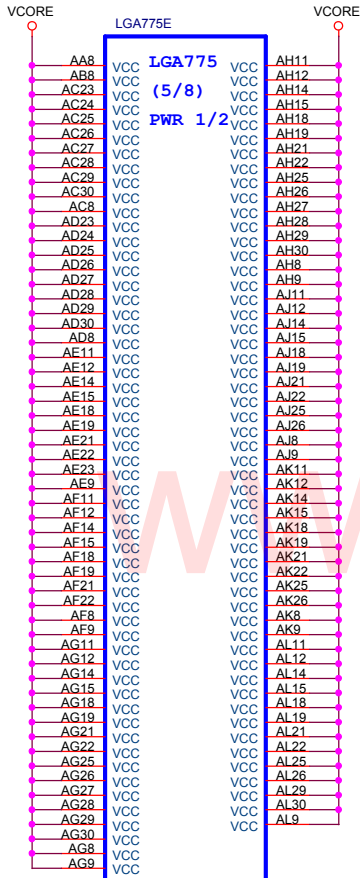

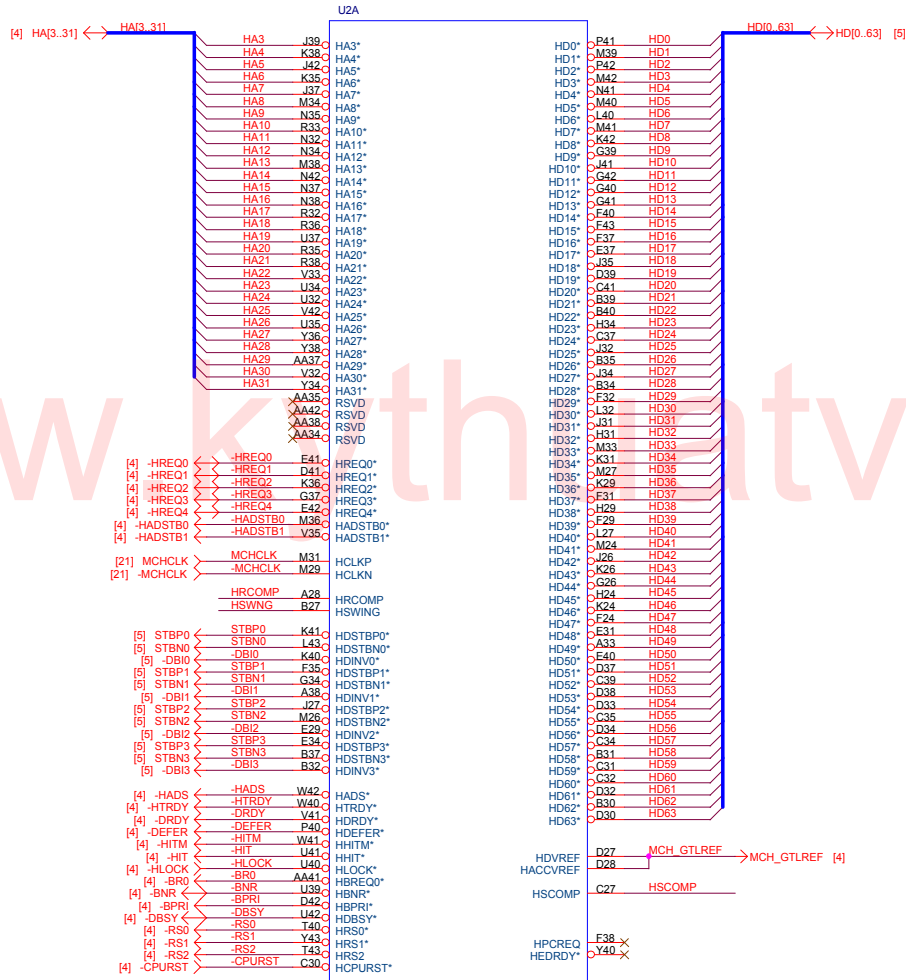

945G/A2[10HB1-033000-22R]
Pb-Free

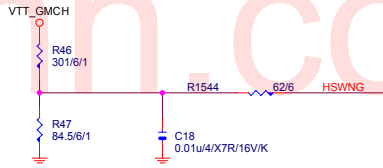
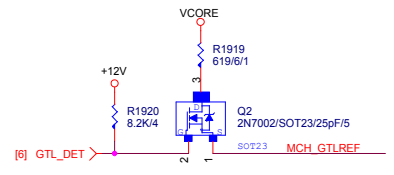
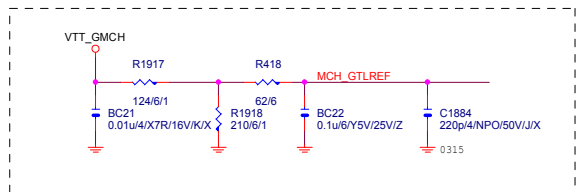
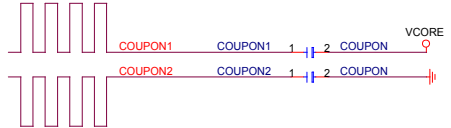

Gigabyte Technology		
Title GMCH-HOST		
Size Custom	Document Number 945GM-DS2	Rev 2.0
Date: Wednesday, November 08, 2006	Sheet 8	of 34

MODT_A0_3] ↔ MODT_A0_3] [15,17]

MODT_B0_3] ↔ MODT_B0_3] [16,17]

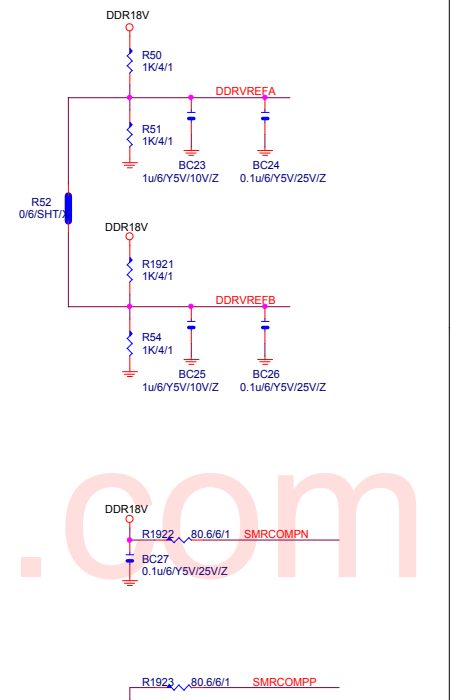
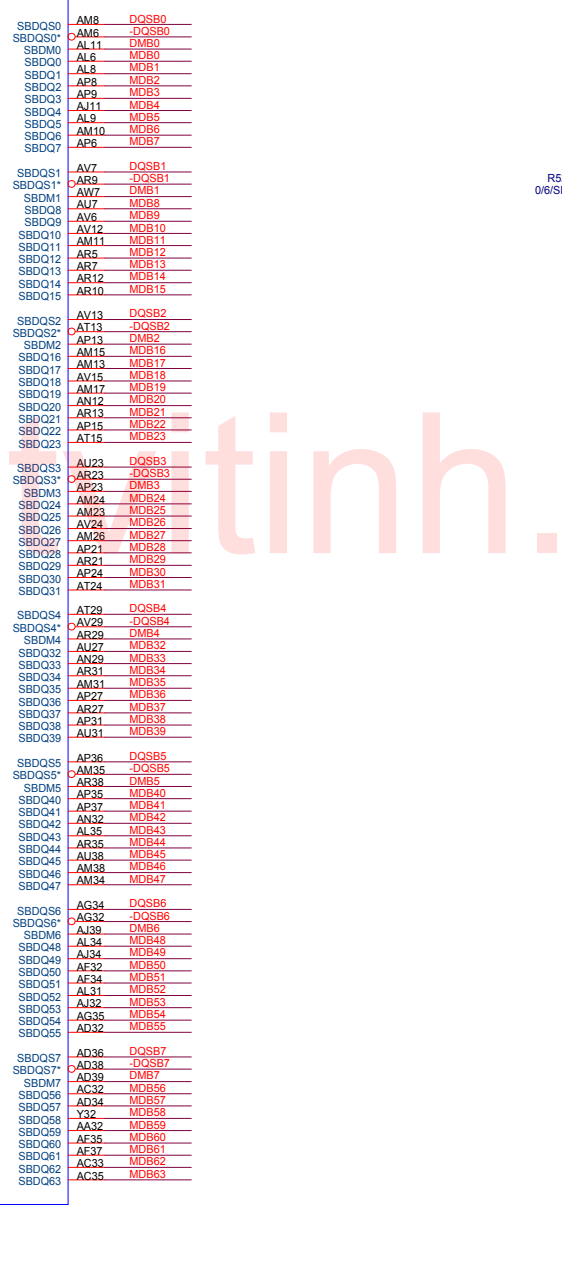
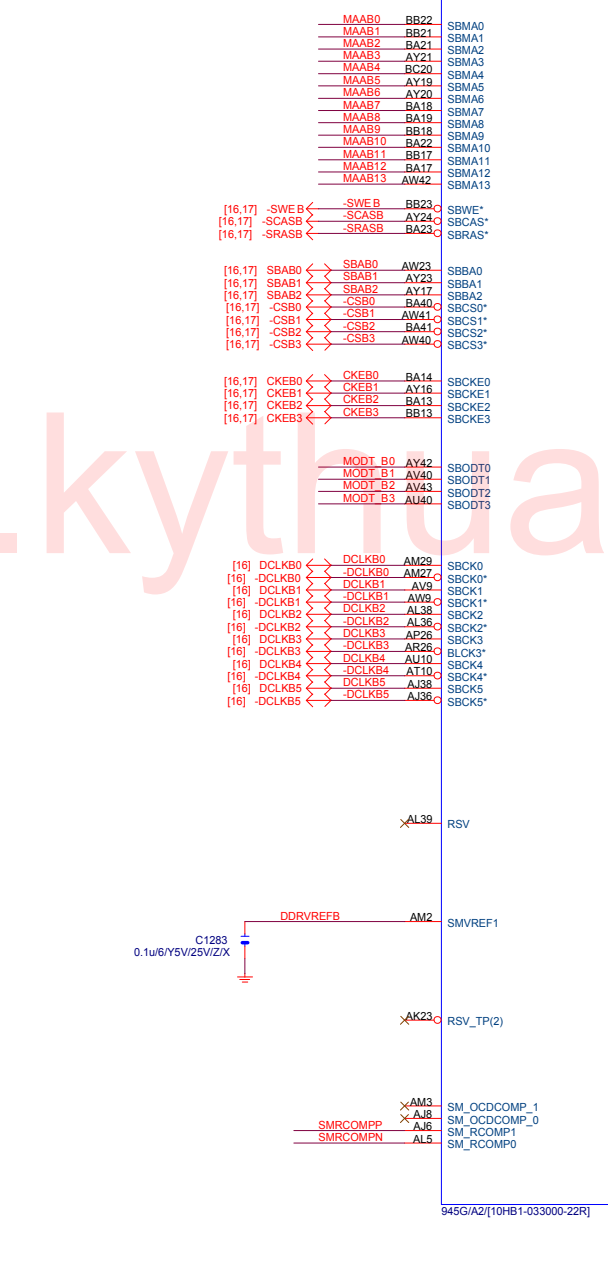
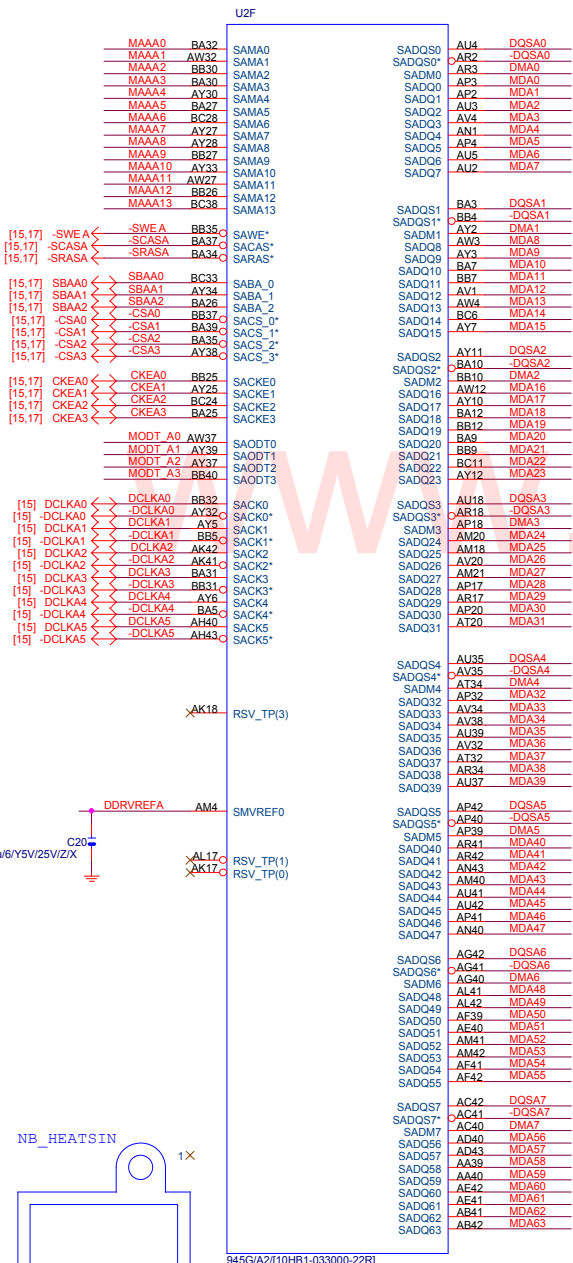

- [16] -DQSB[0..7] ↔ -DQSB0_7I
- [16,17] MAA[B0..13] ↔ MAA[B0..13]I
- [16] DMB[0..7] ↔ DMB[0..7]I
- [16] MDB[0..63] ↔ MDB[0..63]I
- [16] DQSB[0..7] ↔ DQSB[0..7]I
- [15,17] MAA[A0..13] ↔ MAA[A0..13]I
- [15] DMA[0..7] ↔ DMA[0..7]I
- [15] MDA[0..63] ↔ MDA[0..63]I
- [15] DQSA[0..7] ↔ DQSA[0..7]I
- [15] -DQSA[0..7] ↔ -DQSA[0..7]I

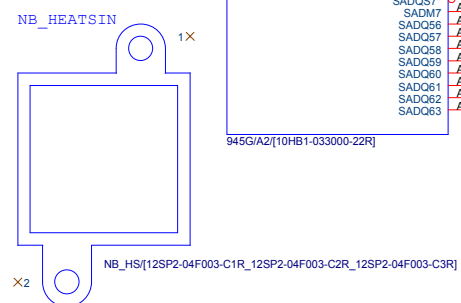

U2B

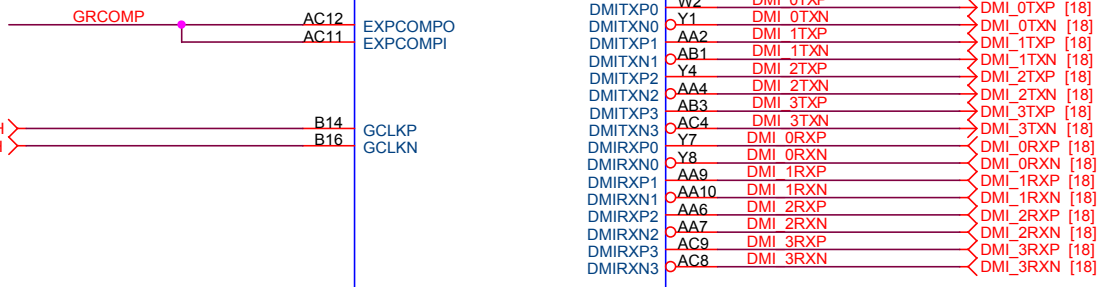
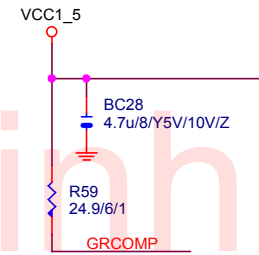
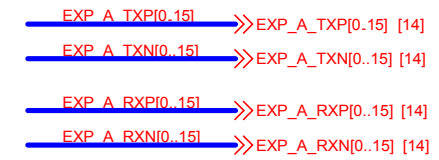
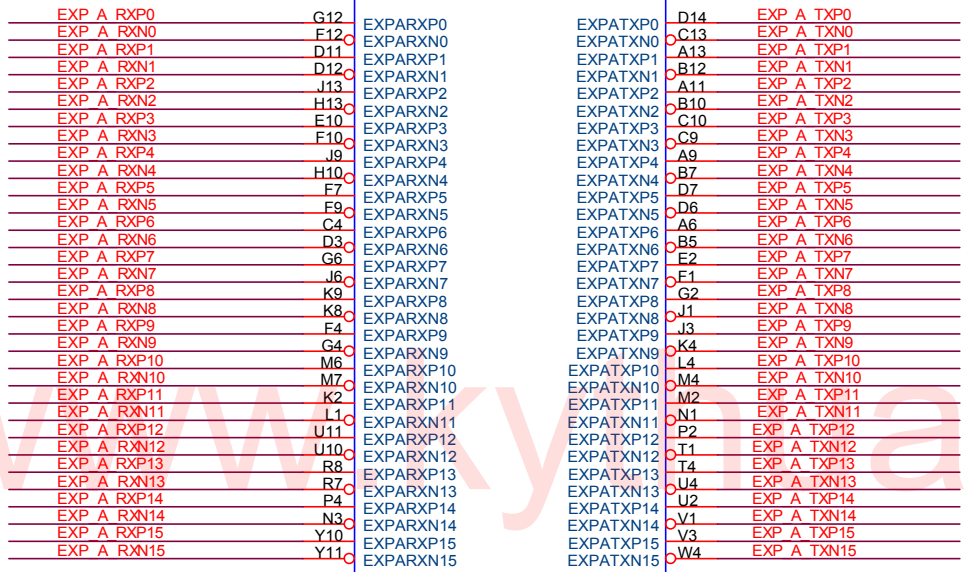

945G/A2{10HB1-033000-22R}

Gigabyte Technology

Title		
GMCH-PCI E & DMI		
Size Custom	Document Number	Rev
	945GM-DS2	2.0
Date:	Wednesday, November 08, 2006	Sheet 10 of 34

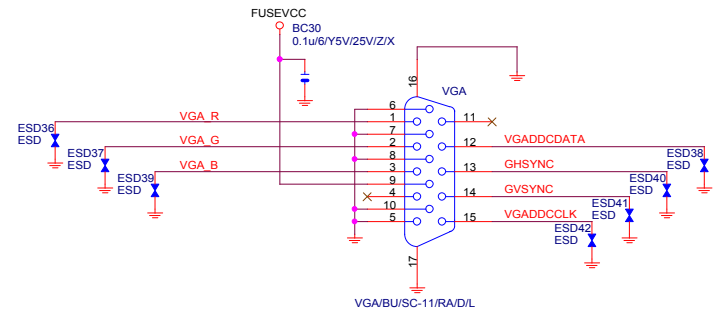
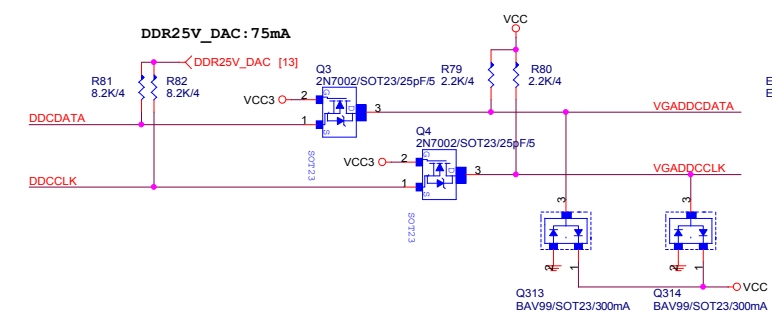
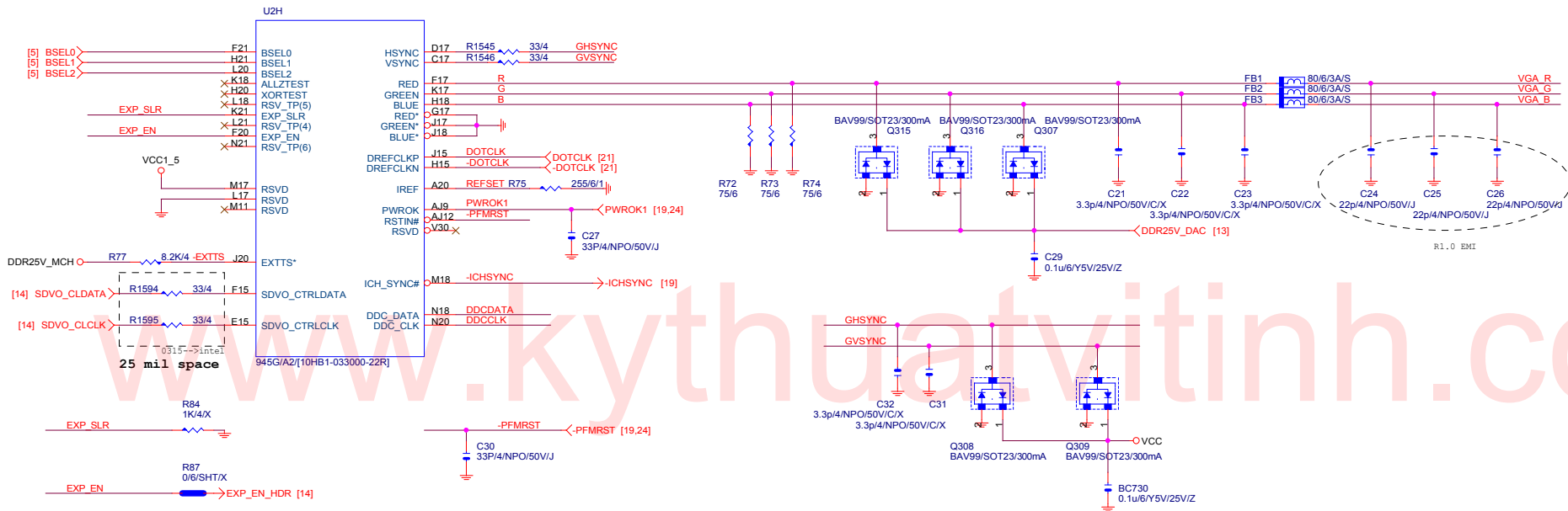

Gigabyte Technology		
Title GMCH-INTERNAL VGA		
Size Custom	Document Number 945GM-DS2	Rev 2.0
Date: Wednesday, November 08, 2006	Sheet 11	of 34

U2C

A4	VSS	N2
A16	VSS	N6
A22	VSS	N8
A26	VSS	N13
A31	VSS	N15
A35	VSS	N24
B4	VSS	N26
B6	VSS	N27
B9	VSS	N29
B11	VSS	N31
B13	VSS	N33
B21	VSS	N36
B22	VSS	N39
B28	VSS	N43
B33	VSS	P3
B38	VSS	P14
C3	VSS	P15
C5	VSS	P24
C7	VSS	P26
C12	VSS	P27
C14	VSS	P29
C22	VSS	P30
C40	VSS	R6
D2	VSS	R9
D5	VSS	R12
D10	VSS	R14
D16	VSS	R30
D20	VSS	R31
D21	VSS	R34
E3	VSS	R37
E4	VSS	R39
E7	VSS	T2
E9	VSS	T2
F12	VSS	T2
F13	VSS	U3
F17	VSS	U5
F18	VSS	U9
F20	VSS	U12
F21	VSS	U14
F32	VSS	U31
F2	VSS	U33
F6	VSS	U36
F18	VSS	U38
F26	VSS	V2
F34	VSS	V8
F42	VSS	V11
G3	VSS	V12
G5	VSS	V14
G7	VSS	V14
G9	VSS	V36
G10	VSS	V37
G13	VSS	V38
G15	VSS	V39
G18	VSS	V43
G20	VSS	W3
G21	VSS	Y2
G24	VSS	Y5
G27	VSS	Y6
G29	VSS	Y9
G31	VSS	Y12
G32	VSS	Y14
G35	VSS	Y31
G38	VSS	Y35
H12	VSS	Y39
H17	VSS	Y42
H26	VSS	Y42
H27	VSS	AA3
H32	VSS	AA8
J2	VSS	AA11
J5	VSS	AA12
J7	VSS	AA14
J10	VSS	AA21
J12	VSS	AA23
J21	VSS	AA31
J24	VSS	AA33
J29	VSS	AA36
J38	VSS	AB2
J43	VSS	AB43
K3	VSS	AC3
K5	VSS	AC7
K6	VSS	AC10
K7	VSS	AC14
K10	VSS	AR6
K12	VSS	AR15
K13	VSS	AR20
K15	VSS	AR20
K20	VSS	AR23
K27	VSS	AR31
K32	VSS	AR32
K34	VSS	AR37
K37	VSS	AR39
K39	VSS	AR43
L2	VSS	AT12
L12	VSS	AT17
L13	VSS	AT18
L24	VSS	AT21
L26	VSS	AT23
L29	VSS	AT26
L31	VSS	AT27
L42	VSS	AT31
M3	VSS	AU6
M5	VSS	AU9
M8	VSS	AU12
M9	VSS	AU13
M10	VSS	AU15
M13	VSS	AU17
M20	VSS	AU20
M21	VSS	AD18
M35	VSS	AD20
M37	VSS	AD22
	VSS	AD24
	VSS	AD27
	VSS	AD29
	VSS	AE19
	VSS	AE21
	VSS	AE23
	VSS	AE25
	VSS	AF18
	VSS	AF20
	VSS	AF22
	VSS	AF24
	VSS	AY1
	VSS	BC4

945G/A2[10HB1-033000-22R]

U2E

AD7	VSS	AD7
AD9	VSS	AD9
AD11	VSS	AD11
AD13	VSS	AD13
AD33	VSS	AD33
N24	VSS	N24
AD37	VSS	AD37
AD42	VSS	AD42
N29	VSS	N29
AF2	VSS	AF2
N33	VSS	N33
AF5	VSS	AF5
N39	VSS	N39
AF36	VSS	AF36
P3	VSS	P3
P14	VSS	P14
P15	VSS	P15
AG31	VSS	AG31
AG33	VSS	AG33
AG36	VSS	AG36
AG37	VSS	AG37
AG38	VSS	AG38
AG39	VSS	AG39
AH42	VSS	AH42
AJ7	VSS	AJ7
AJ10	VSS	AJ10
AJ30	VSS	AJ30
AJ31	VSS	AJ31
AJ33	VSS	AJ33
AJ35	VSS	AJ35
AJ37	VSS	AJ37
AK24	VSS	AK24
AK26	VSS	AK26
AK29	VSS	AK29
AK30	VSS	AK30
AL1	VSS	AL1
AL3	VSS	AL3
AL7	VSS	AL7
AL10	VSS	AL10
AL12	VSS	AL12
AL13	VSS	AL13
AL15	VSS	AL15
AL18	VSS	AL18
AL21	VSS	AL21
AL23	VSS	AL23
AL24	VSS	AL24
AL27	VSS	AL27
AL32	VSS	AL32
AL33	VSS	AL33
V38	VSS	V38
V39	VSS	V39
AM5	VSS	AM5
AM7	VSS	AM7
AM8	VSS	AM8
AM33	VSS	AM33
AM36	VSS	AM36
AM37	VSS	AM37
AM39	VSS	AM39
AN2	VSS	AN2
AN4	VSS	AN4
AN13	VSS	AN13
AN15	VSS	AN15
AN17	VSS	AN17
AN18	VSS	AN18
AN20	VSS	AN20
AN21	VSS	AN21
AN23	VSS	AN23
AN24	VSS	AN24
AN14	VSS	AN14
AN27	VSS	AN27
AN31	VSS	AN31
AN42	VSS	AN42
AP5	VSS	AP5
AP7	VSS	AP7
AP10	VSS	AP10
AP12	VSS	AP12
AP29	VSS	AP29
AP34	VSS	AP34
AP38	VSS	AP38
AR1	VSS	AR1
AR6	VSS	AR6
AR15	VSS	AR15
AR20	VSS	AR20
AR20	VSS	AR20
AR23	VSS	AR23
AR24	VSS	AR24
AR32	VSS	AR32
AR37	VSS	AR37
AR39	VSS	AR39
AR43	VSS	AR43
AT12	VSS	AT12
AT17	VSS	AT17
AT18	VSS	AT18
AT21	VSS	AT21
AT23	VSS	AT23
AT26	VSS	AT26
AT27	VSS	AT27
AT31	VSS	AT31
AU6	VSS	AU6
AU9	VSS	AU9
AU12	VSS	AU12
AU13	VSS	AU13
AU15	VSS	AU15
AU17	VSS	AU17
AU20	VSS	AU20
AD18	VSS	AD18
AD20	VSS	AD20
AD22	VSS	AD22
AD24	VSS	AD24
AD27	VSS	AD27
AD29	VSS	AD29
AE19	VSS	AE19
AE21	VSS	AE21
AE23	VSS	AE23
AE25	VSS	AE25
AF18	VSS	AF18
AF20	VSS	AF20
AF22	VSS	AF22
AF24	VSS	AF24
AY1	VSS	AY1
BC4	VSS	BC4

VSS	AU21
VSS	AU24
VSS	AU26
VSS	AU29
VSS	AU32
VSS	AU34
VSS	AV2
VSS	AV10
VSS	AV17
VSS	AV37
VSS	AW10
VSS	BA4
VSS	BA42
VSS	BB3
VSS	BB6
VSS	BB11
VSS	BB14
VSS	BB19
VSS	BB34
VSS	BB39
VSS	BB41
VSS	BC9
VSS	A40
VSS	D1
VSS	D43
VSS	R26
VSS	R29
VSS	U29
VSS	V24
VSS	V26
VSS	V29
VSS	W21
VSS	W23
VSS	W25
VSS	Y20
VSS	Y22
VSS	Y24
VSS	Y26
VSS	Y29
VSS	AA25
VSS	AA27
VSS	AA29
VSS	AC19
VSS	AC26
VSS	AC29
NC	A42
NC	B2
NC	B3
NC	B4
NC	B42
NC	B43
NC	C2
NC	C42
NC	E36
NC	AV26
NC	AV27
NC	AW2
NC	AW26
NC	BA2
NC	BB1
NC	BB2
NC	BB43
NC	BC1
NC	BC2
NC	BC42
NC	BC43
RSVD	AK21
RSVD	AJ23
RSVD	AJ26
RSVD	AL20
RSVD	AL20
RSVD	AJ21
RSVD	AL26
RSVD	AK27
RSVD	AD30
RSVD	AC34
RSVD	Y30
RSVD	Y31
RSVD	AF31
RSVD	AD31
RSVD	U30
RSVD	V31
RSVD	AA30
RSVD	AC30
RSVD	AA3
RSVD	AG28
RSVD	AG28
RSVD	AG27
RSVD	AJ29
RSVD	AJ27
RSVD	AK40
RSVD	AW17
RSVD	AW19
RSVD	AY14
RSVD	BC16
RSVD	AJ29
RSVD	AG29

www.lythuaivinh.com

1.425~1.575V

- VCC1_5
- N17 VCC
- P17 VCC
- P20 VCC
- P21 VCC
- AA22 VCC
- AB21 VCC
- AB22 VCC
- AB23 VCC
- AC22 VCC
- AD14 VCC
- AF6 VCC
- AF7 VCC
- AF8 VCC
- AF9 VCC
- AF10 VCC
- AF11 VCC
- AF12 VCC
- AF13 VCC
- AF14 VCC
- AF30 VCC
- AG2 VCC
- AG3 VCC
- AG4 VCC
- AG5 VCC
- AG6 VCC
- AG7 VCC
- AG8 VCC
- AG9 VCC
- AG10 VCC
- AG11 VCC
- AG12 VCC
- AG13 VCC
- AG14 VCC
- AH1 VCC
- AH2 VCC
- AH4 VCC
- AJ5 VCC
- AJ13 VCC
- AJ14 VCC
- AK3 VCC
- AK4 VCC
- AK14 VCC
- AK15 VCC
- AK20 VCC
- R15 VCC
- R17 VCC
- R18 VCC
- R20 VCC
- R21 VCC
- R23 VCC
- R24 VCC
- U15 VCC
- U17 VCC
- U18 VCC
- U19 VCC
- U20 VCC
- U21 VCC
- U22 VCC
- U23 VCC
- U24 VCC
- U25 VCC
- U26 VCC
- W15 VCC
- W19 VCC
- W18 VCC
- W20 VCC
- W22 VCC
- W24 VCC
- W26 VCC
- W27 VCC
- Y15 VCC
- Y17 VCC
- Y18 VCC
- Y19 VCC
- Y21 VCC
- Y26 VCC
- Y27 VCC
- AA15 VCC
- AA17 VCC
- AA18 VCC
- AA19 VCC
- AA20 VCC
- AA24 VCC
- AA26 VCC
- AB17 VCC
- AB18 VCC
- AB19 VCC
- AB20 VCC
- AB24 VCC
- AB25 VCC
- AB26 VCC
- AB27 VCC
- AC15 VCC
- AC17 VCC
- AC18 VCC
- AC20 VCC
- AC24 VCC
- AC26 VCC
- AC27 VCC
- AD15 VCC
- AD17 VCC
- AD19 VCC
- AD21 VCC
- AD23 VCC
- AD25 VCC
- AD26 VCC
- AE17 VCC
- AE18 VCC
- AE20 VCC
- AE22 VCC
- AE24 VCC
- AE26 VCC
- AE27 VCC
- AF15 VCC
- AF17 VCC
- AF19 VCC
- AF21 VCC
- AF23 VCC
- AF25 VCC
- AF26 VCC
- AF27 VCC
- AF29 VCC

U2D

1.7~1.9V

- VCCSM BB16
- VCCSM AW15
- VCCSM BB42
- VCCSM BC13
- VCCSM BC18
- VCCSM BC22
- VCCSM BC26
- VCCSM BB20
- VCCSM AW24
- VCCSM B046
- VCCSM BC31
- VCCSM BB38
- VCCSM BB33
- VCCSM BB28
- VCCSM BB24
- VCCSM AW29
- VCCSM AW31
- VCCSM AW34
- VCCSM AX41
- VCCSM AW42
- VCCSM AW23
- VCCSM AW18
- VCCSM BC40
- VCCSM AW35
- VCCSM AX43
- VCCSM AW20
- VCCSM AW21
- VCCSM AW13
- VCCSM AW21

1.14~1.26V

- VTT C23
- VTT G23
- VTT P23
- VTT E23
- VTT D23
- VTT D24
- VTT D25
- VTT B25
- VTT B24
- VTT B23
- VTT H23
- VTT J23
- VTT K23
- VTT L23
- VTT M23
- VTT E24
- VTT N23
- VTT A24
- VTT F27
- VTT E27
- VTT E26
- VTT C25
- VTT C26
- VTT C28
- VTT VTT

1.425~1.575V

- VCC EXP AA13
- VCC EXP AD12
- VCC EXP AC5
- VCC EXP AA5
- VCC EXP U13
- VCC EXP V5
- VCC EXP V13
- VCC EXP R13
- VCC EXP N12
- VCC EXP N10
- VCC EXP N7
- VCC EXP N11
- VCC EXP AE3
- VCC EXP N9
- VCC EXP AD10
- VCC EXP AD1
- VCC EXP AC8
- VCC EXP AD8
- VCC EXP AD2
- VCC EXP AD4
- VCC EXP AD5
- VCC EXP AD6
- VCC EXP Y13
- VCC EXP N6
- VCC EXP U8
- VCC EXP AC13
- VCC EXP AE4
- VCC EXP U7
- VCC EXP R10
- VCC EXP U6
- VCC EXP V6
- VCC EXP Y7
- VCC EXP V9
- VCC EXP V10

VCC1_5

VCC1_5

VCC1_5

VCC1_5

VCC1_5

VCC1_5

VCC1_5

VCC1_5

VCC1_5

VCC1_5

VCC1_5

VCC1_5

VCC1_5

VCC1_5

VCCA_EXPPLL=VCCA_GPLL=45mA (1.425V~1.575V)



VCCA_HPLL>50mA 公板為200mA (1.425V~1.575V)



VCCA_DPLLA=65mA (1.425V~1.575V)



VCCA_DPLLB=65mA (1.425V~1.575V)



VCCA_MPLL>50mA (1.425V~1.575V)



2.375~2.625V

VCCA_DAC=DDR25V_DAC=70mA (2.375~2.625V)

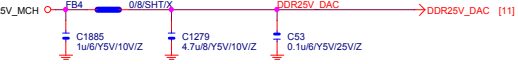

VCC1_5

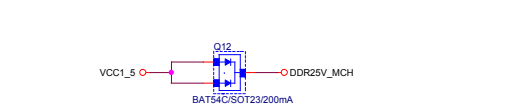
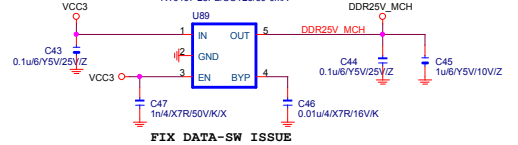

945 Design Guide rev1.5 spec.
 VCCA_EXPPLL=VCCA_GPLL=45mA (1.425V~1.575V)
 VCCA_HPLL>50mA 公板為200mA (1.425V~1.575V)
 VCCA_DPLLA=65mA (1.425V~1.575V)
 VCCA_DPLLB=65mA (1.425V~1.575V)
 VCCA_MPLL>50mA (1.425V~1.575V)
 VCCA_DAC=DDR25V_DAC=70mA (2.375~2.625V)

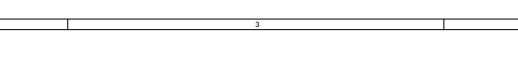
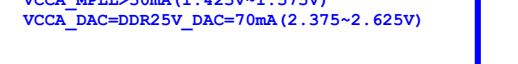
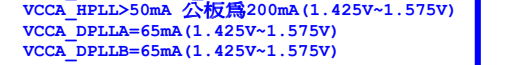
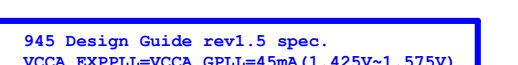
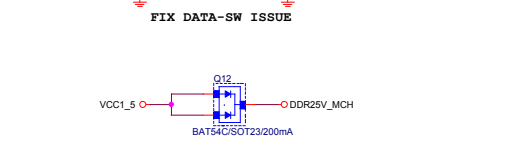
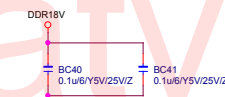
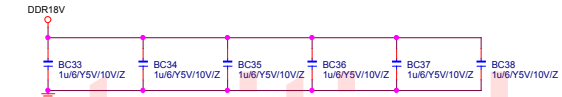
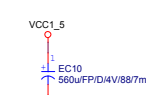
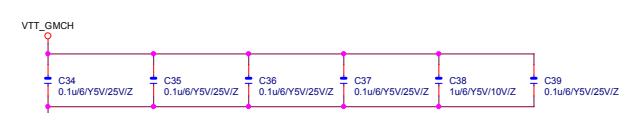

Gigabyte Technology		
File	GMCH-PWR	
Size	Document Number	Rev
Custom	945GM-DS2	2.0
Date:	Wednesday, November 08, 2006	Sheet 13 of 34

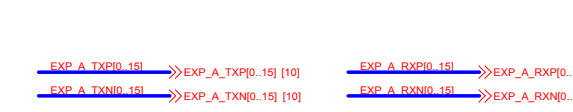
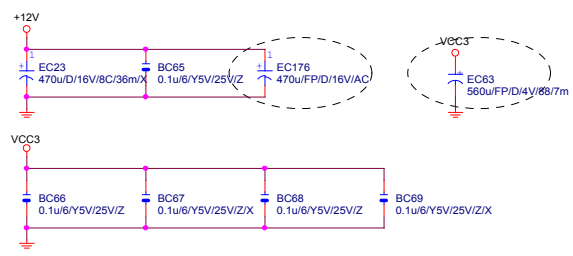

EXP A TXP0	C92	0.1uF/4/YSV/16V/Z	EXP A TXP0C
EXP A TXN0	C93	0.1uF/4/YSV/16V/Z	EXP A TXN0C
EXP A TXP1	C94	0.1uF/4/YSV/16V/Z	EXP A TXP1C
EXP A TXN1	C95	0.1uF/4/YSV/16V/Z	EXP A TXN1C
EXP A TXP2	C96	0.1uF/4/YSV/16V/Z	EXP A TXP2C
EXP A TXN2	C97	0.1uF/4/YSV/16V/Z	EXP A TXN2C
EXP A TXP3	C98	0.1uF/4/YSV/16V/Z	EXP A TXP3C
EXP A TXN3	C99	0.1uF/4/YSV/16V/Z	EXP A TXN3C
EXP A TXP4	C100	0.1uF/4/YSV/16V/Z	EXP A TXP4C
EXP A TXN4	C101	0.1uF/4/YSV/16V/Z	EXP A TXN4C
EXP A TXP5	C102	0.1uF/4/YSV/16V/Z	EXP A TXP5C
EXP A TXN5	C103	0.1uF/4/YSV/16V/Z	EXP A TXN5C
EXP A TXP6	C104	0.1uF/4/YSV/16V/Z	EXP A TXP6C
EXP A TXN6	C105	0.1uF/4/YSV/16V/Z	EXP A TXN6C
EXP A TXP7	C106	0.1uF/4/YSV/16V/Z	EXP A TXP7C
EXP A TXN7	C107	0.1uF/4/YSV/16V/Z	EXP A TXN7C
EXP A TXP8	C108	0.1uF/4/YSV/16V/Z	EXP A TXP8C
EXP A TXN8	C109	0.1uF/4/YSV/16V/Z	EXP A TXN8C
EXP A TXP9	C110	0.1uF/4/YSV/16V/Z	EXP A TXP9C
EXP A TXN9	C111	0.1uF/4/YSV/16V/Z	EXP A TXN9C
EXP A TXP10	C112	0.1uF/4/YSV/16V/Z	EXP A TXP10C
EXP A TXN10	C113	0.1uF/4/YSV/16V/Z	EXP A TXN10C
EXP A TXP11	C114	0.1uF/4/YSV/16V/Z	EXP A TXP11C
EXP A TXN11	C115	0.1uF/4/YSV/16V/Z	EXP A TXN11C
EXP A TXP12	C116	0.1uF/4/YSV/16V/Z	EXP A TXP12C
EXP A TXN12	C117	0.1uF/4/YSV/16V/Z	EXP A TXN12C
EXP A TXP13	C118	0.1uF/4/YSV/16V/Z	EXP A TXP13C
EXP A TXN13	C119	0.1uF/4/YSV/16V/Z	EXP A TXN13C
EXP A TXP14	C120	0.1uF/4/YSV/16V/Z	EXP A TXP14C
EXP A TXN14	C121	0.1uF/4/YSV/16V/Z	EXP A TXN14C
EXP A TXP15	C122	0.1uF/4/YSV/16V/Z	EXP A TXP15C
EXP A TXN15	C123	0.1uF/4/YSV/16V/Z	EXP A TXN15C

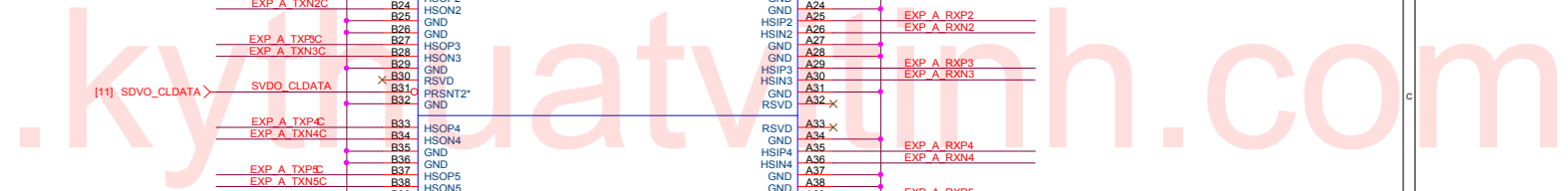
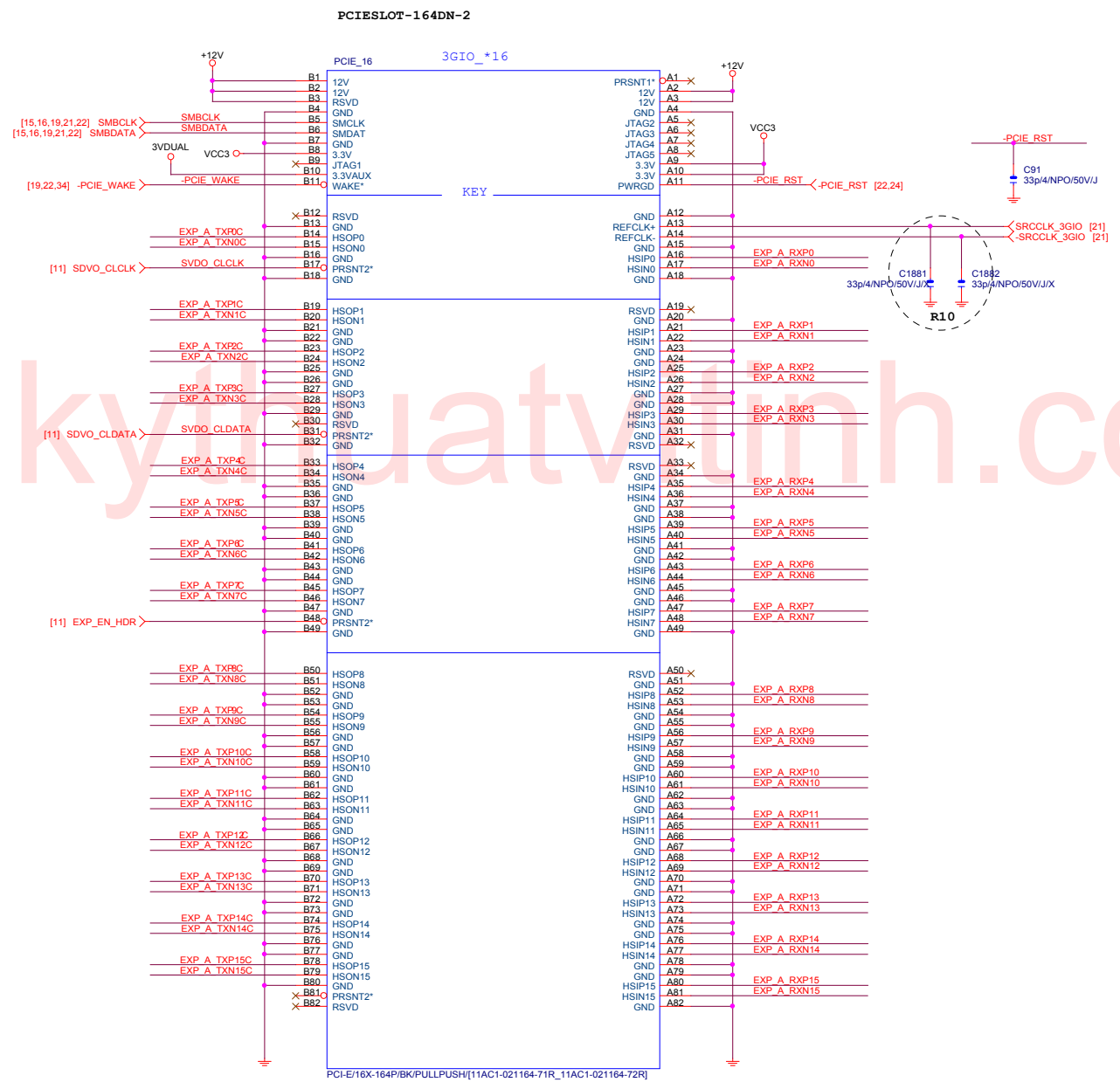

Gigabyte Technology		
PCI EXPRESS * 16		
Size Custom	Document Number	Rev
	945GM-DS2	2.0
Date:	Wednesday, November 08, 2006	Sheet 14 of 34

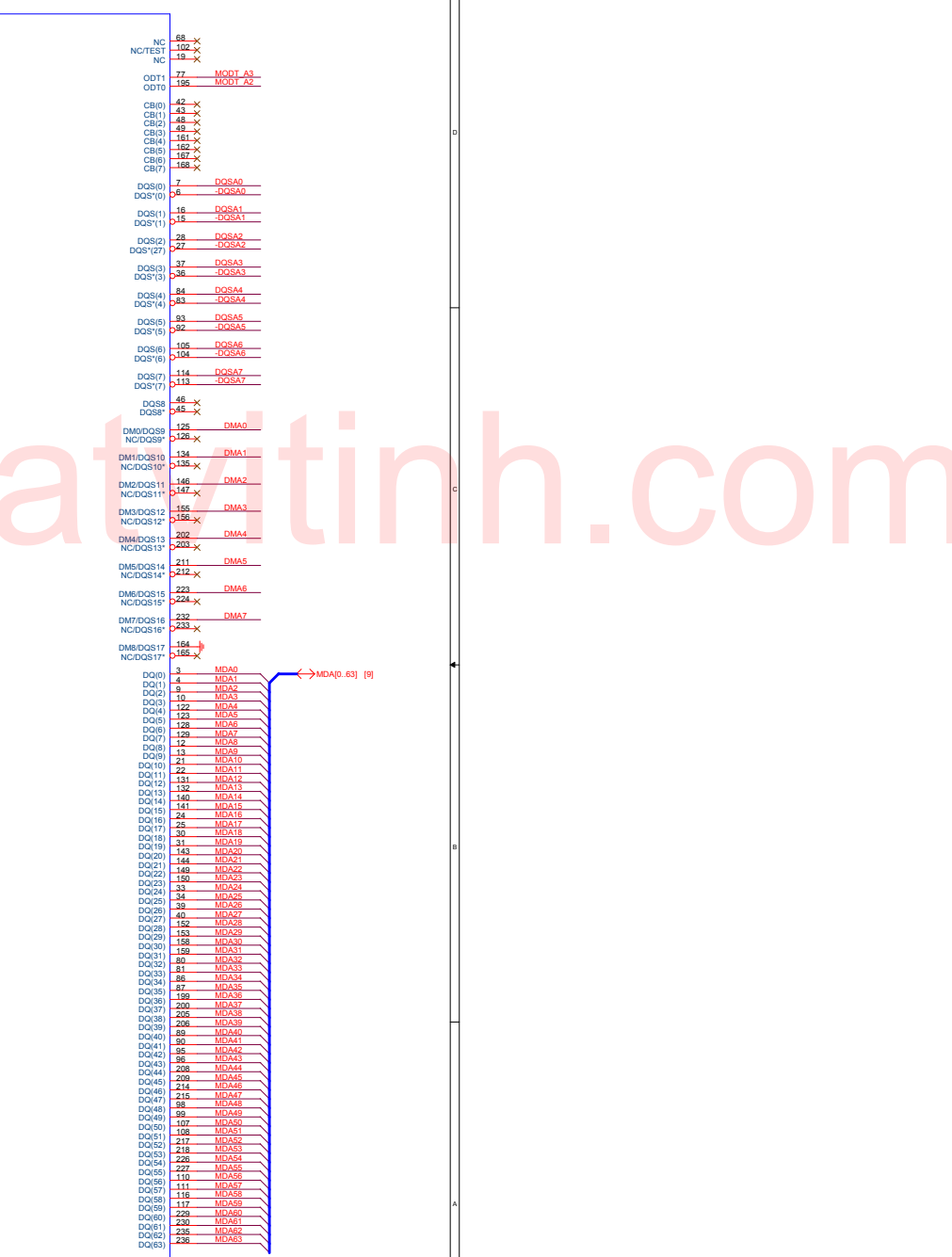
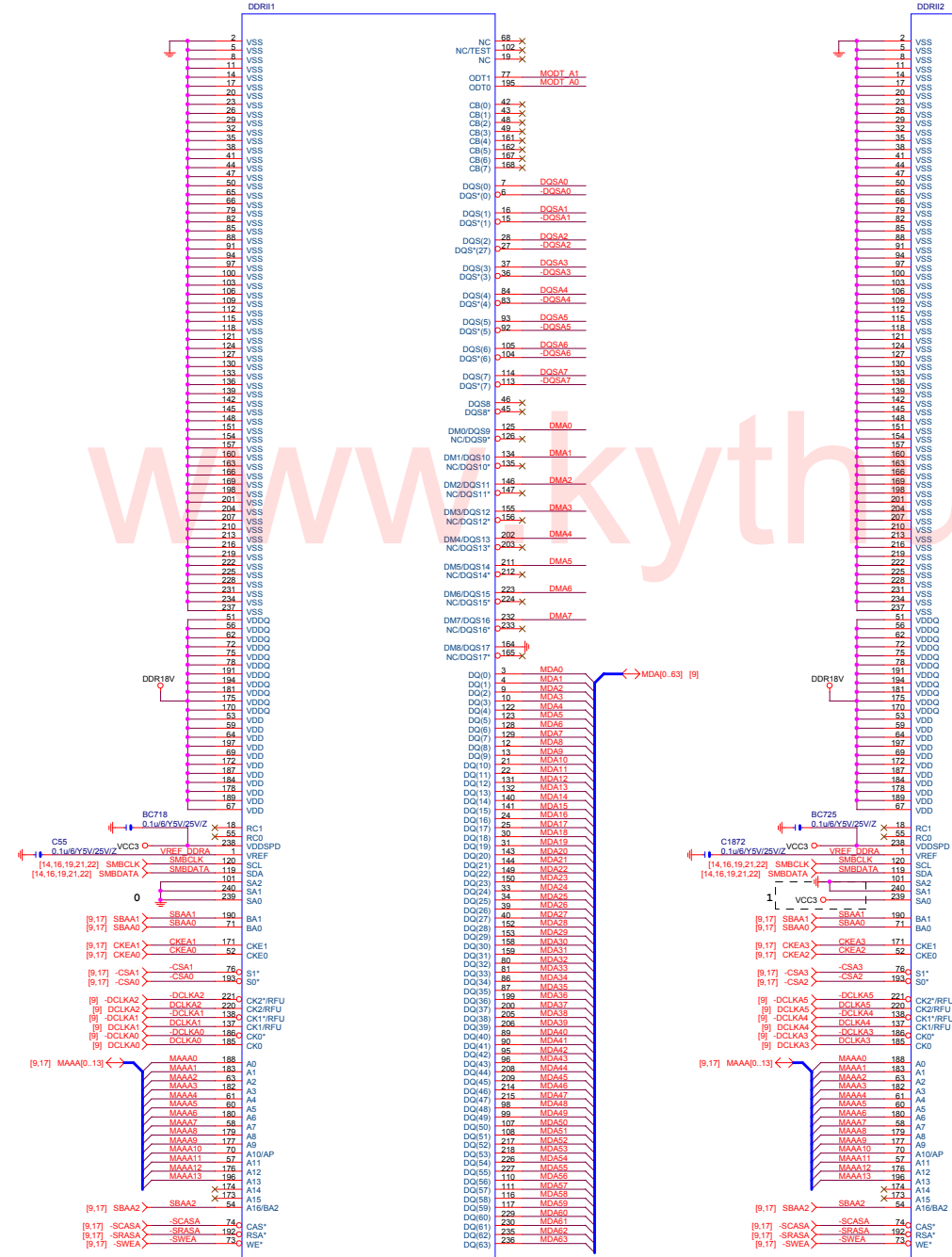

MDT_A0[0..3] ↔ MDT_A0[0..3] [9]
 DQSA0[0..7] ↔ DQSA0[0..7] [9]
 DQSA0[7] ↔ DQSA0[0..7] [9]
 DMA0[0..7] ↔ DMA0[0..7] [9]

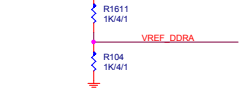

DDR TERMINATION CHANNEL A

DDRVTT Decouple

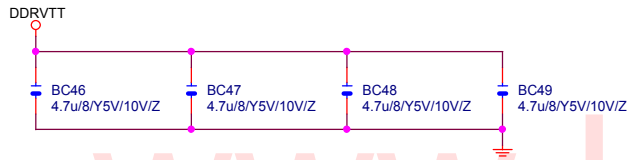
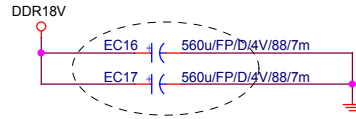
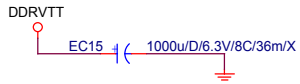

DDR18V Decouple

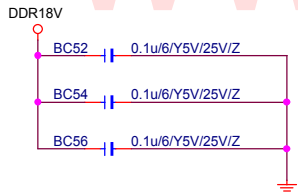

DDRVTT Decouple

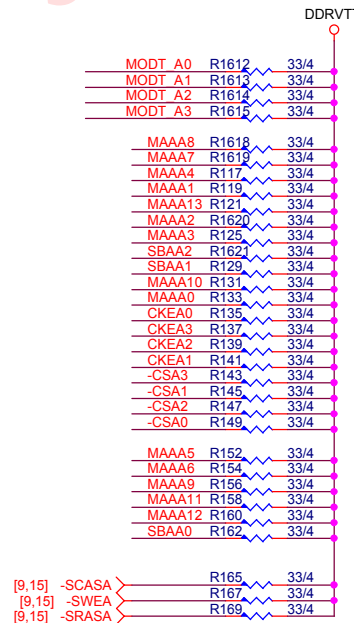
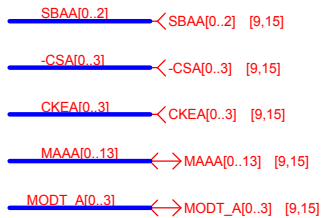
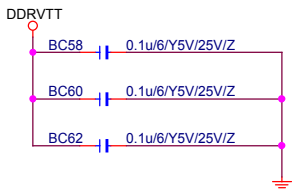

DDR TERMINATION CHANNEL B

DDR18V Decouple

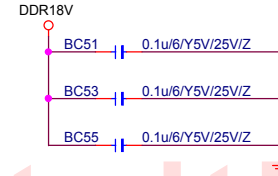

DDRVTT Decouple

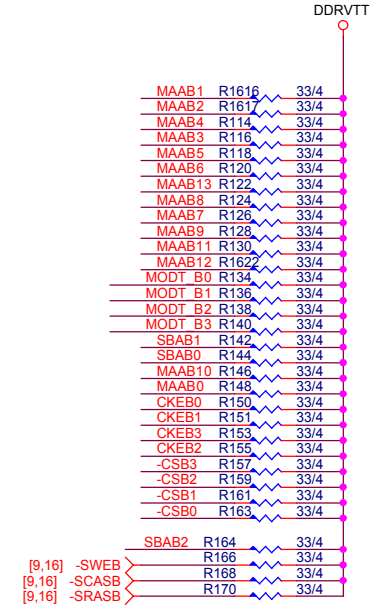
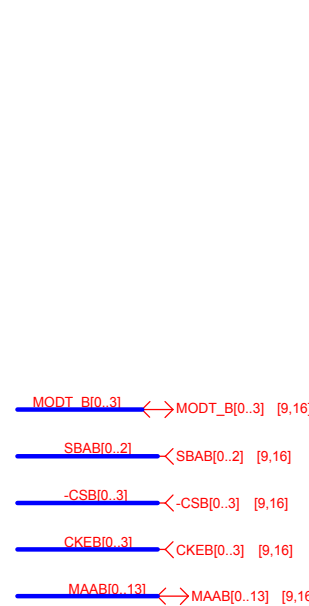
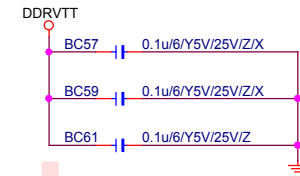

Gigabyte Technology

Title			DDRII TERMINATOR		
Size	Document Number	945GM-DS2			Rev
Custom					2.0
Date:	Wednesday, November 08, 2006	Sheet	17	of	34

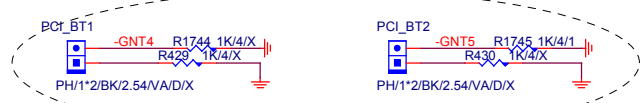
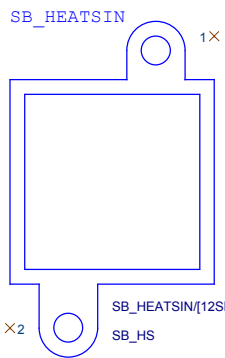
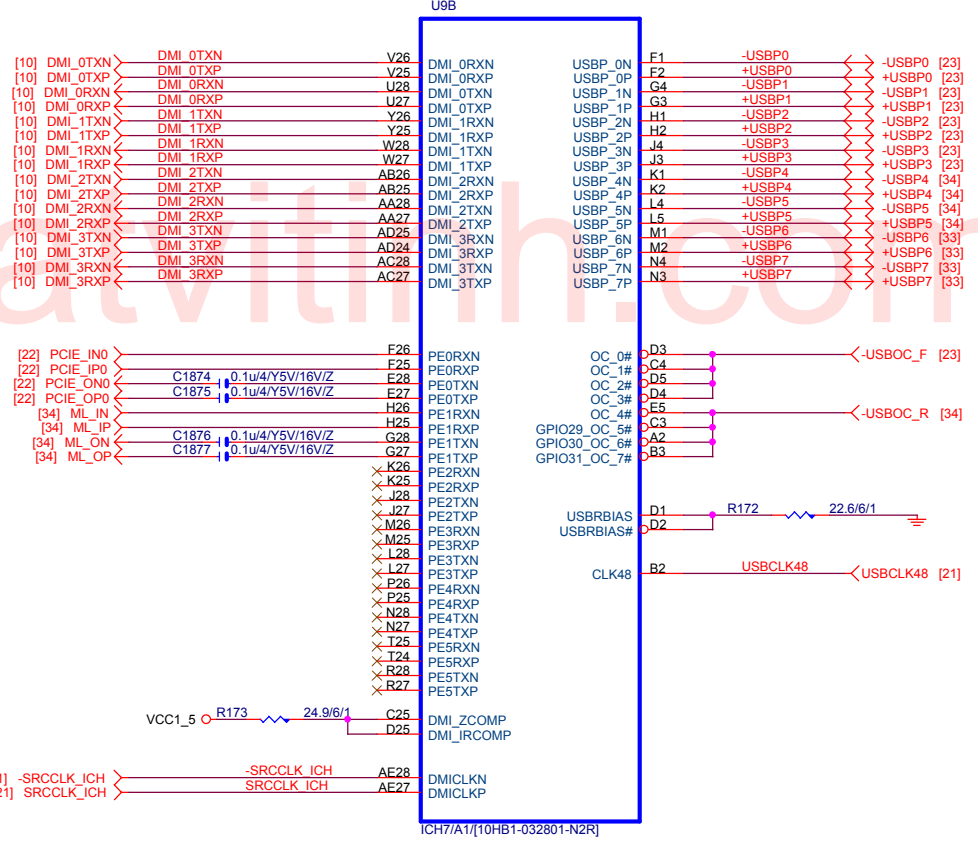
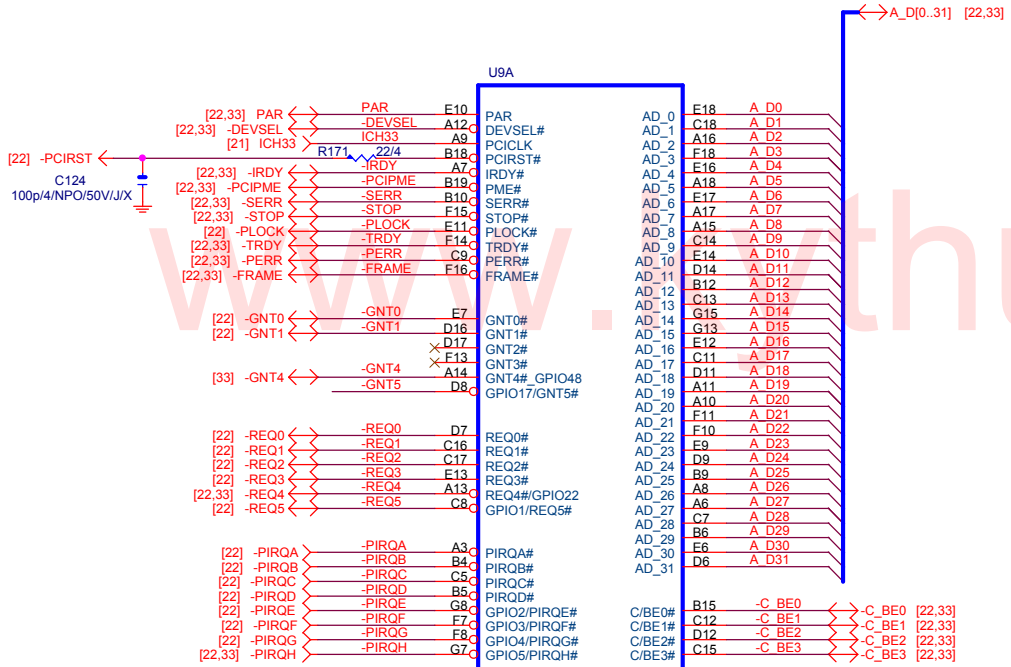

Gigabyte Technology		
Title ICH7-PCI, DMI, LAN, USB		
Size B	Document Number 945GM-DS2	Rev 2.0
Date:	Wednesday, November 08, 2006	Sheet 18 of 34

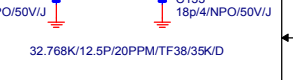
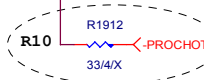
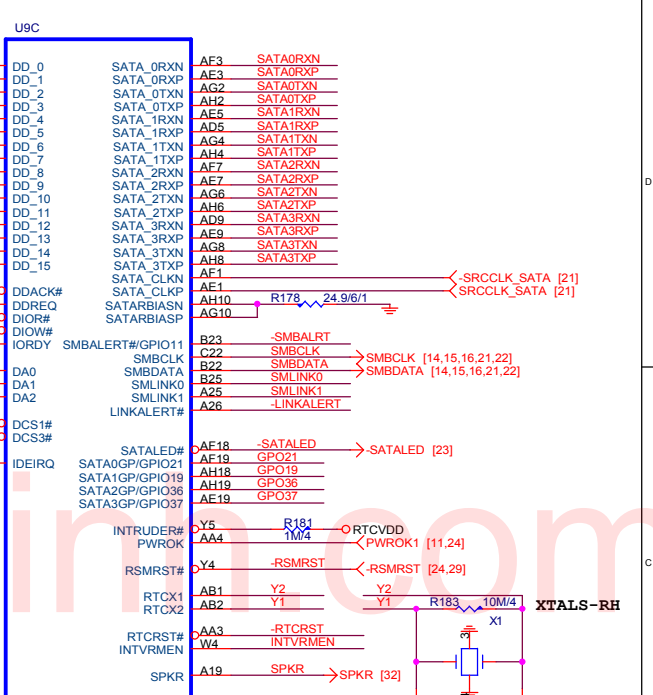
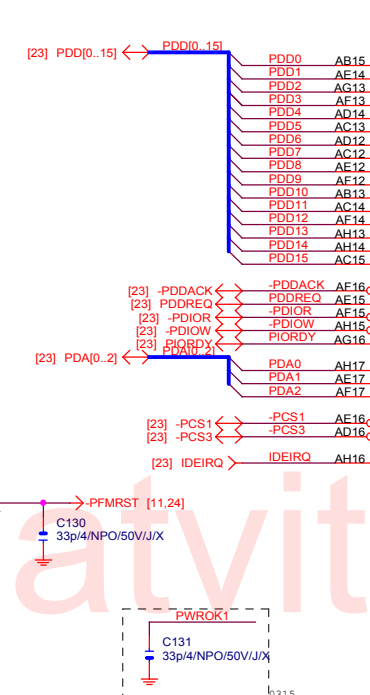
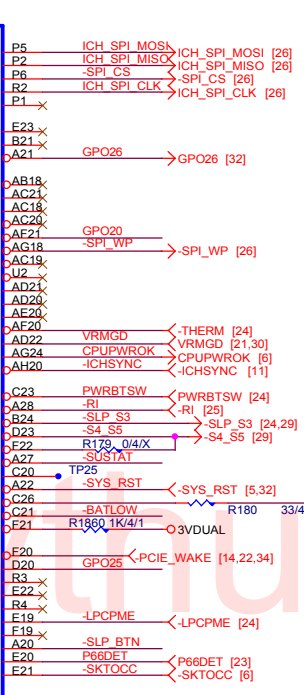
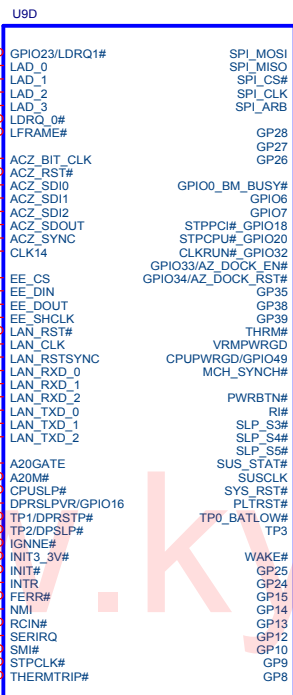

NEW TYPE: BATTERY-DUAL-4

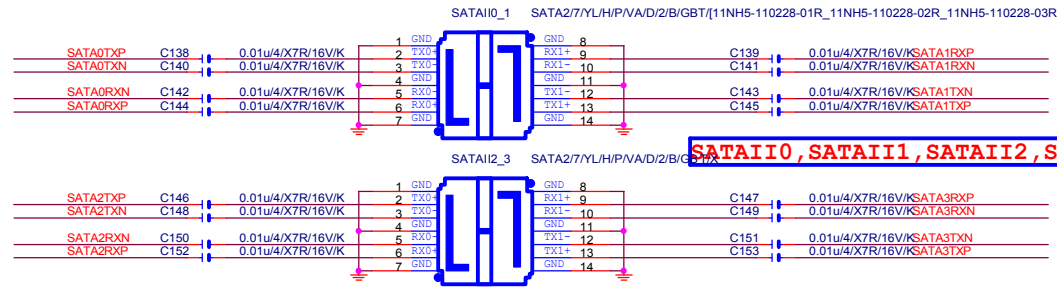
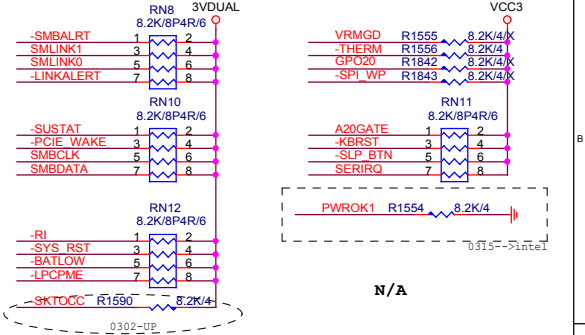
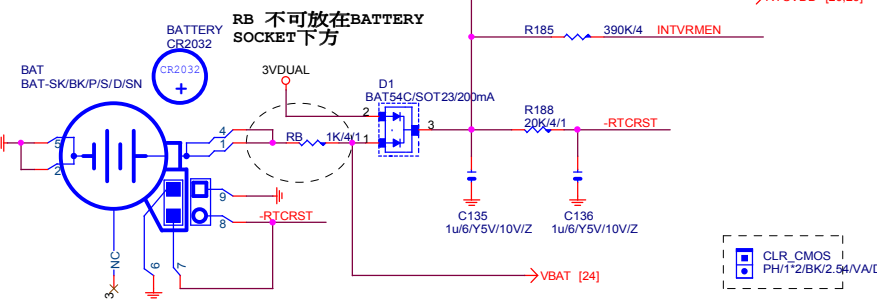

SATAI0, SATAI1, SATAI2, SATAI3 文字面各別分開

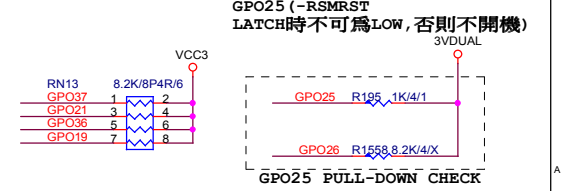

U9F		
A4	VSS1	VSS101
A23	VSS2	VSS102
B1	VSS3	VSS103
B8	VSS4	VSS104
B11	VSS5	VSS105
B14	VSS6	VSS106
B17	VSS7	VSS107
B20	VSS8	VSS108
B26	VSS9	VSS109
B28	VSS10	VSS110
C2	VSS11	VSS111
C6	VSS12	VSS112
D10	VSS13	VSS113
D13	VSS14	VSS114
D18	VSS15	VSS115
D21	VSS16	VSS116
D24	VSS17	VSS117
E1	VSS18	VSS118
E2	VSS19	VSS119
E8	VSS20	VSS120
F15	VSS21	VSS121
F3	VSS22	VSS122
F4	VSS23	VSS123
F12	VSS24	VSS124
F27	VSS25	VSS125
F28	VSS26	VSS126
G1	VSS27	VSS127
G1	VSS28	VSS128
G2	VSS29	VSS129
G5	VSS30	VSS130
G6	VSS31	VSS131
G9	VSS32	VSS132
G14	VSS33	VSS133
G18	VSS34	VSS134
G21	VSS35	VSS135
G24	VSS36	VSS136
G25	VSS37	VSS137
G26	VSS38	VSS138
H3	VSS39	VSS139
H4	VSS40	VSS140
H5	VSS41	VSS141
H24	VSS42	VSS142
H27	VSS43	VSS143
H28	VSS44	VSS144
J1	VSS45	VSS145
J2	VSS46	VSS146
J5	VSS47	VSS147
J25	VSS48	VSS148
J25	VSS49	VSS149
J26	VSS50	VSS150
K24	VSS51	VSS151
K27	VSS52	VSS152
K28	VSS53	VSS153
L13	VSS54	VSS154
L15	VSS55	VSS155
L24	VSS56	VSS156
L25	VSS57	VSS157
L26	VSS58	VSS158
M3	VSS59	VSS159
M4	VSS60	VSS160
M5	VSS61	VSS161
M12	VSS62	VSS162
M13	VSS63	VSS163
M14	VSS64	VSS164
M15	VSS65	VSS165
M16	VSS66	VSS166
M17	VSS67	VSS167
M24	VSS68	VSS168
M27	VSS69	VSS169
M28	VSS70	VSS170
N1	VSS71	VSS171
N2	VSS72	VSS172
N5	VSS73	VSS173
N6	VSS74	VSS174
N11	VSS75	VSS175
N12	VSS76	VSS176
N13	VSS77	VSS177
N14	VSS78	VSS178
N15	VSS79	VSS179
N16	VSS80	VSS180
N17	VSS81	VSS181
N18	VSS82	VSS182
N24	VSS83	VSS183
N26	VSS84	VSS184
P3	VSS85	VSS185
P4	VSS86	VSS186
P12	VSS88	VSS188
P13	VSS89	VSS189
P14	VSS90	VSS190
P15	VSS91	VSS191
P16	VSS92	VSS192
P17	VSS93	VSS193
P24	VSS94	VSS194
P27	VSS95	VSS195
P28	VSS96	VSS196
R1	VSS97	VSS197
R11	VSS98	VSS198
R12	VSS99	VSS199
R13	VSS100	VSS200

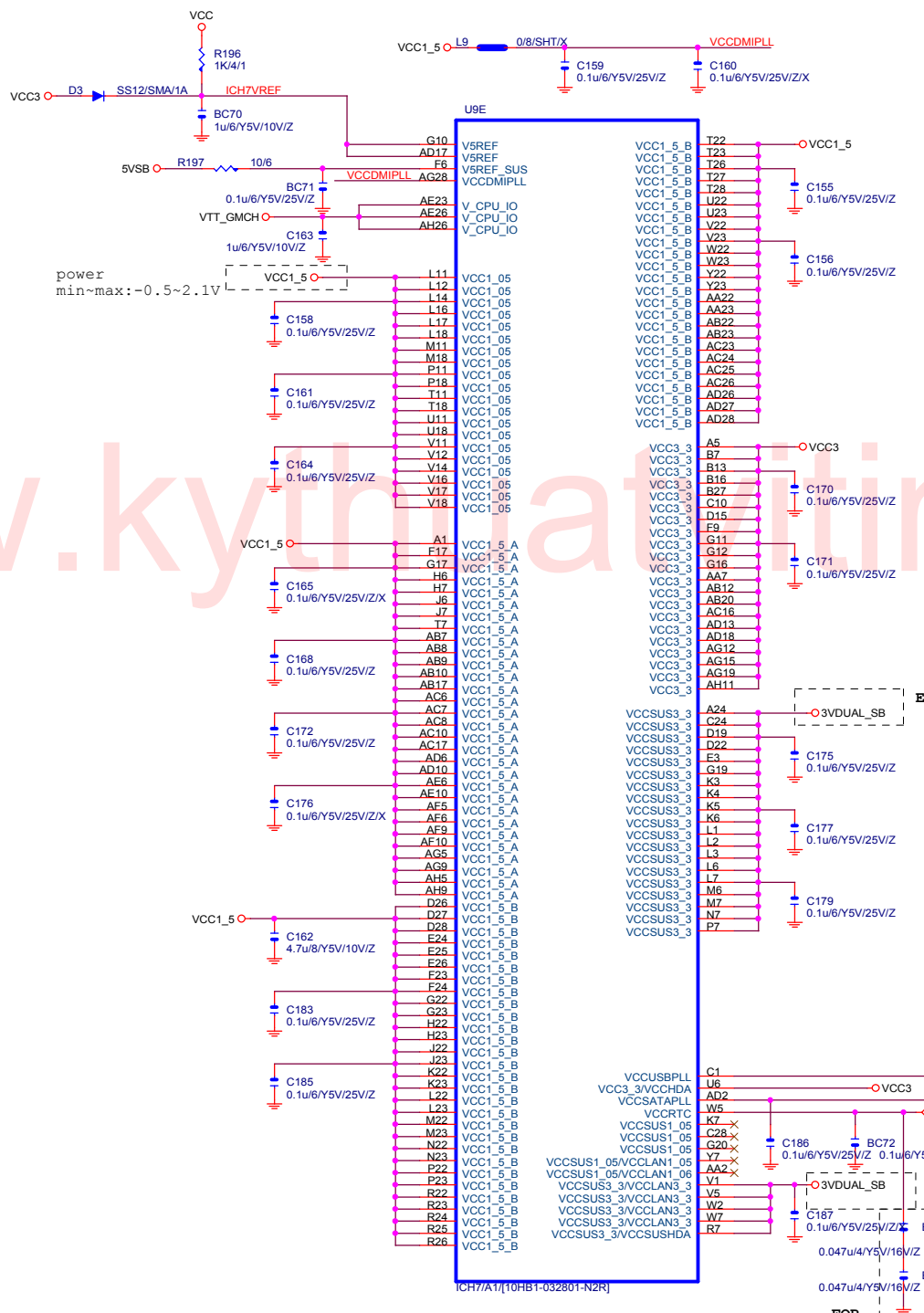

www.kytech.com

Gigabyte Technology		
ICH7-PWR & GND		
Size B	Document Number	Rev
	945GM-DS2	2.0
Date:	Wednesday, November 08, 2006	Sheet 20 of 34

FOR 漏電

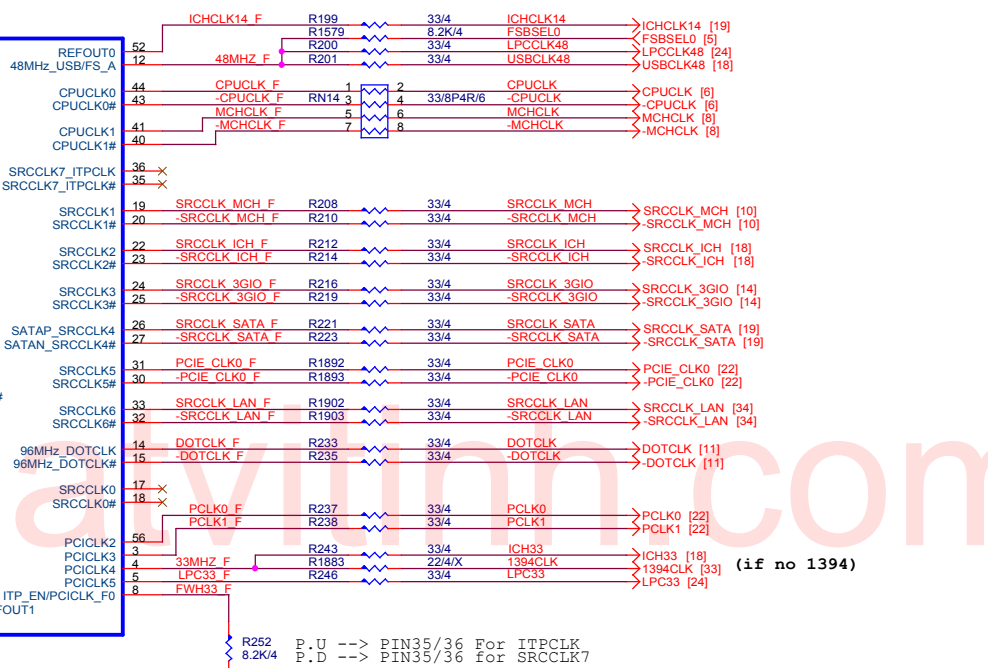
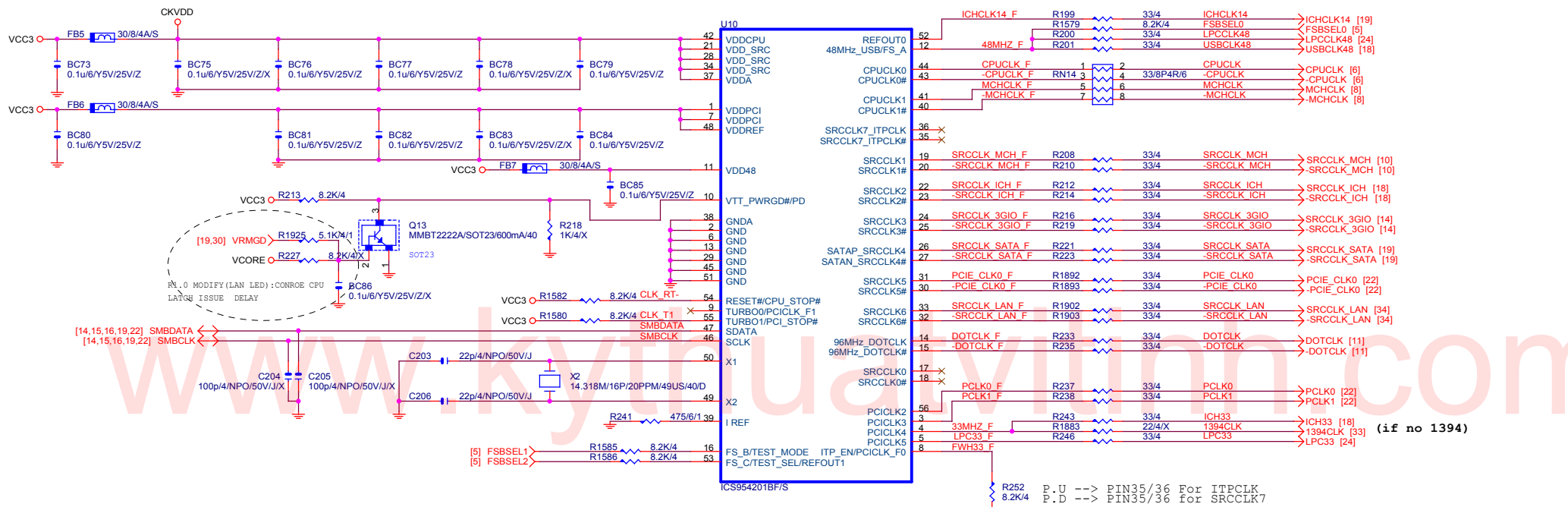

R252 8.2K/4 P.U --> PIN35/36 For ITPCLK
 P.D --> PIN35/36 for SRCCLK7

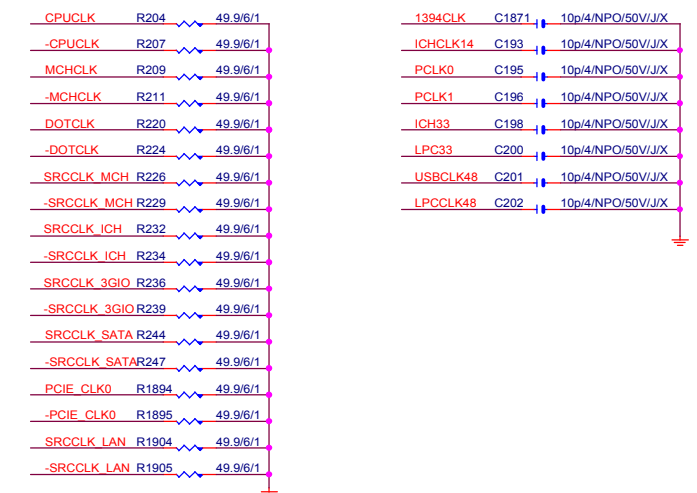

PCI1, 2 SLOT

PCIEX*1

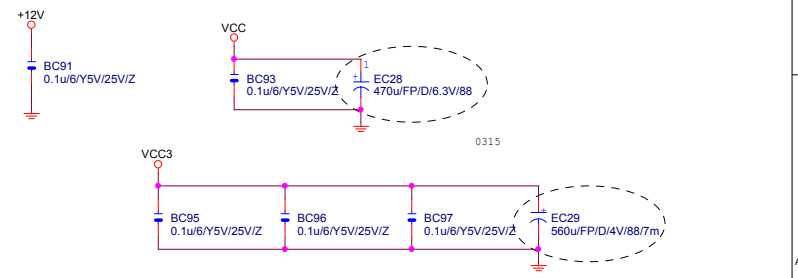
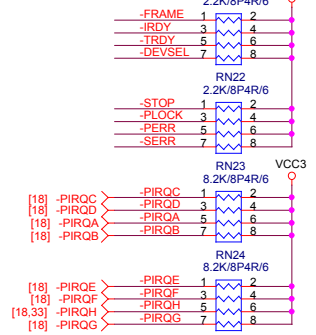
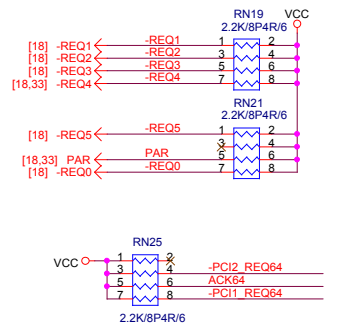
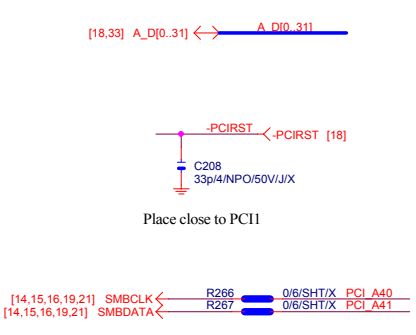
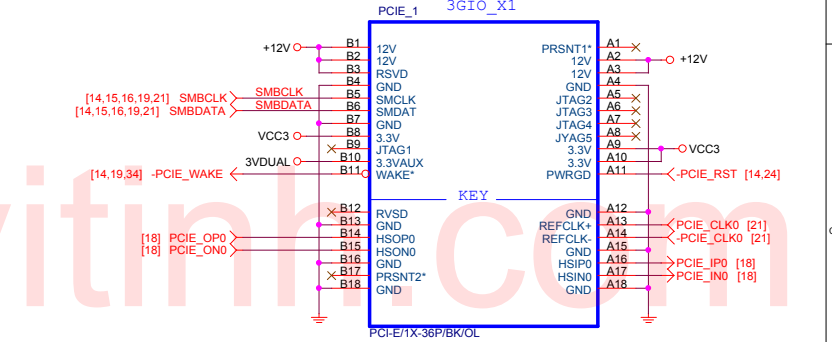
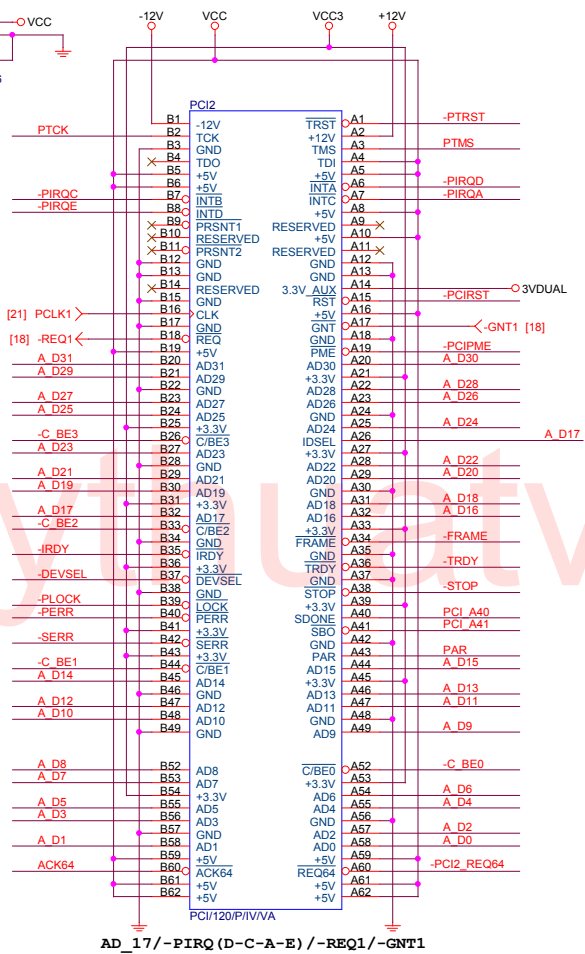
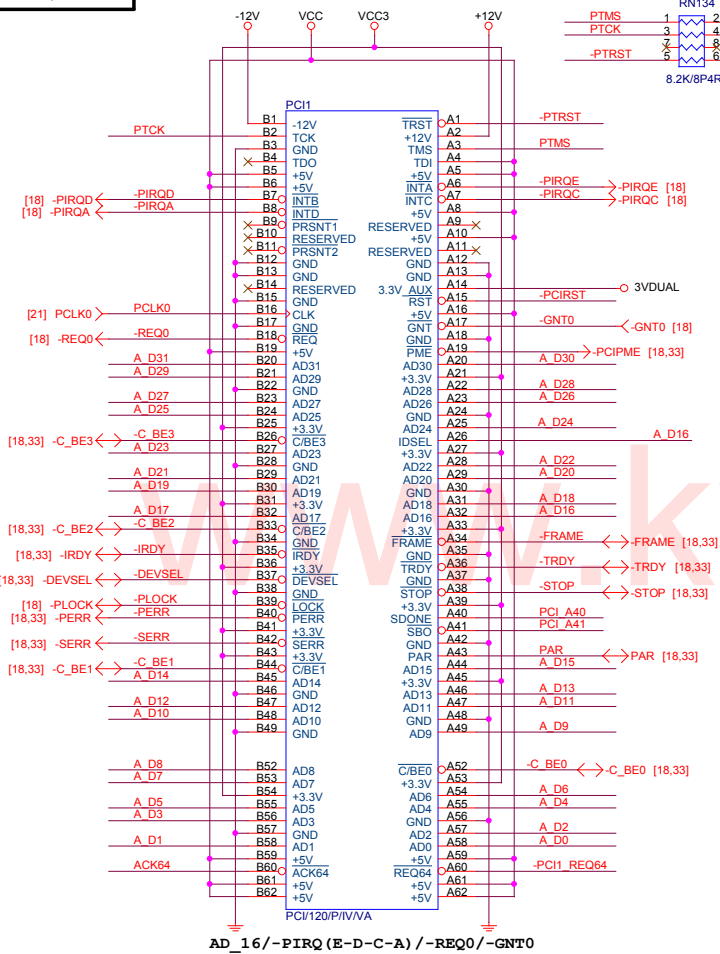

Gigabyte Technology		
PCI SLOT 1, 2/PCIEX1		
945GM-DS2		Rev 2.0
Size	Document Number	
Custor		
Date:	Wednesday, November 08, 2006	Sheet 22 of 34

IDE/SATA LED

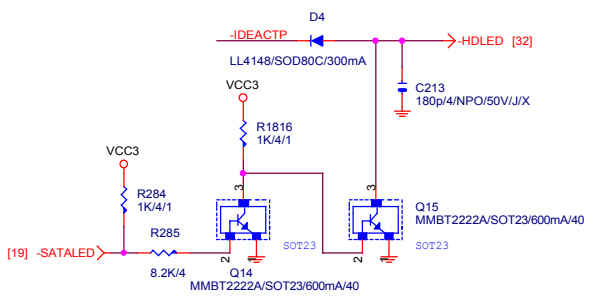

IDE RESET

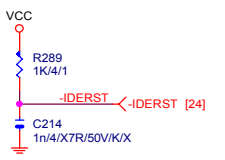

FLOPPY

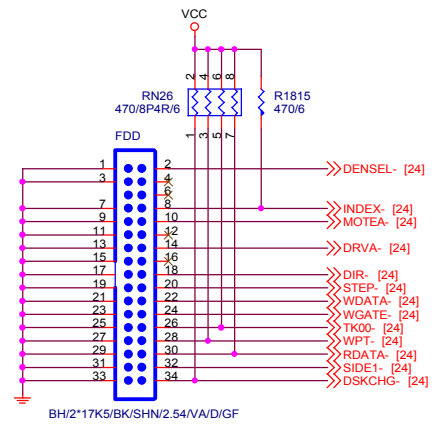

IDE

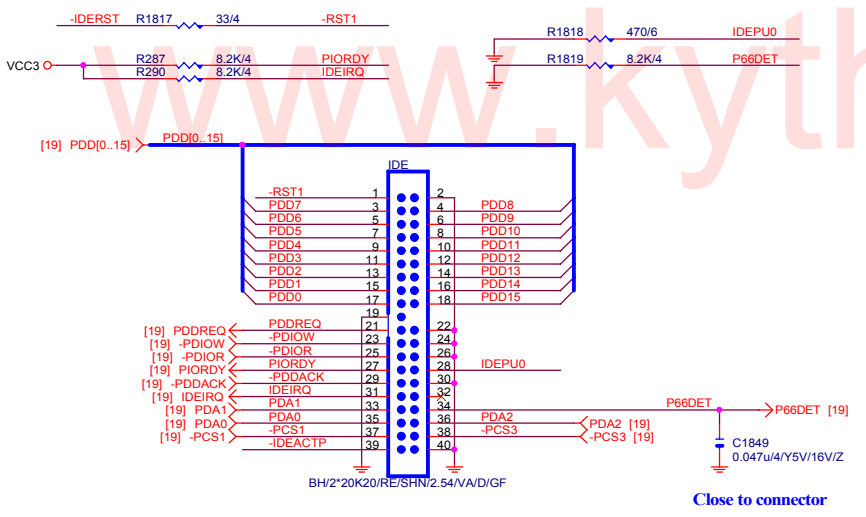

FRONT USB1

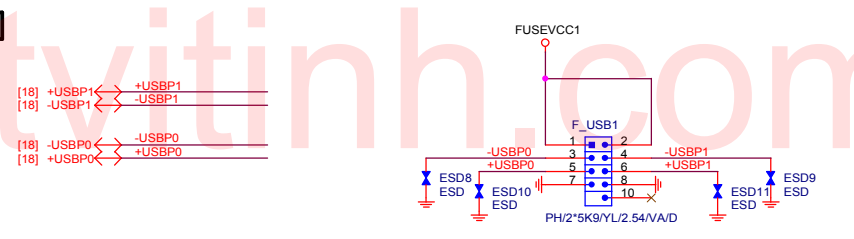

FRONT USB2

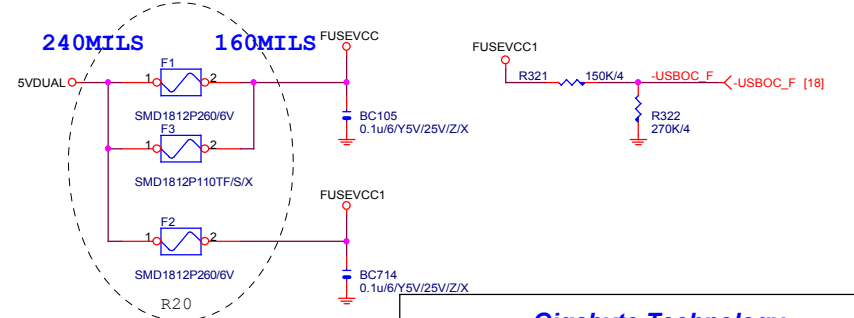
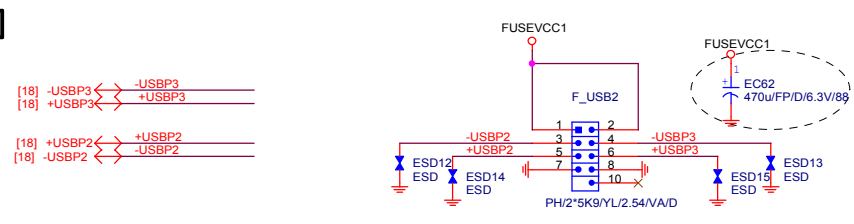

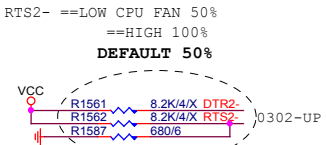

SOUT2	1	VID pins threshold voltage select: Vih/Vil : 2.0/0.8V
	0	VID pins threshold voltage select: Vih/Vil : 0.8/0.4V

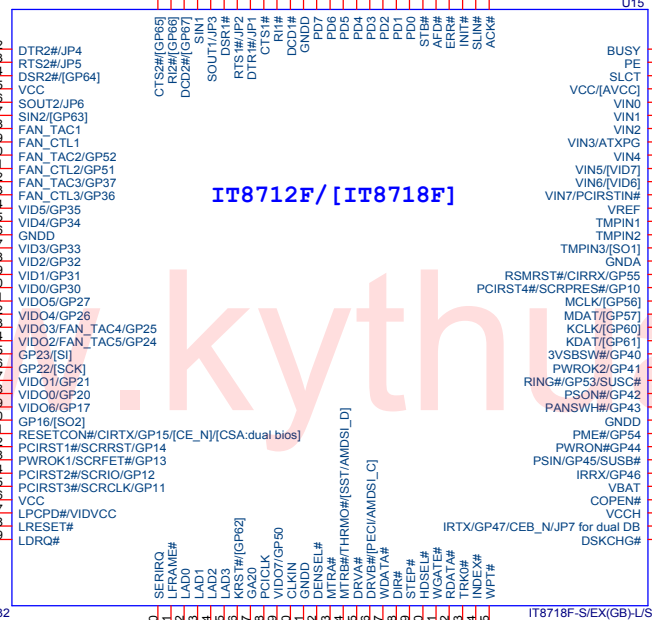
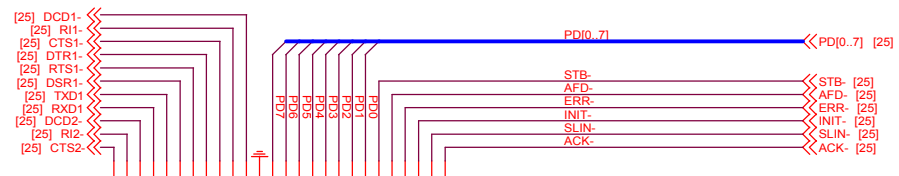
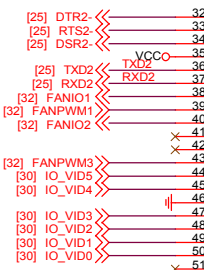

**JP7 : HIGH DUAL BIOS DISABLE
 LOW DUAL BIOS ENABLE**

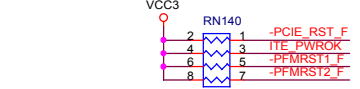
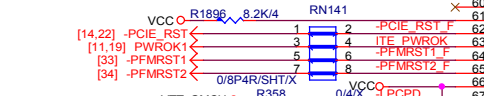

**1.2V or 3.3V tolerance select.
 1.2V OUTPUT 接 VTT_GMCH
 3.3V OUTPUT 接 3.3V
 LPCPD#=#VIDVCC**

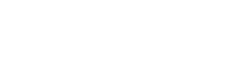
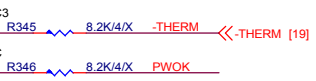

COMA

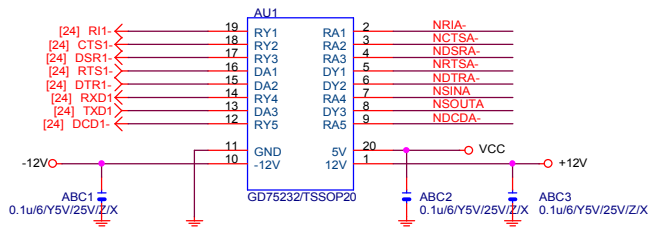

RING IN

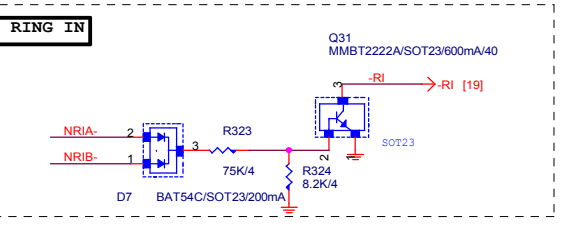

EXTERNAL COMA

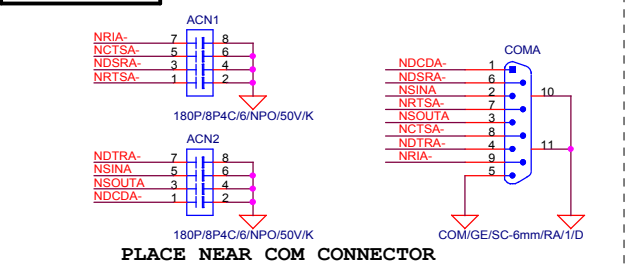

COMB

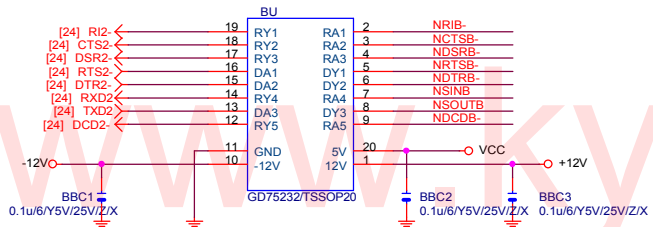

INTERNAL COMB

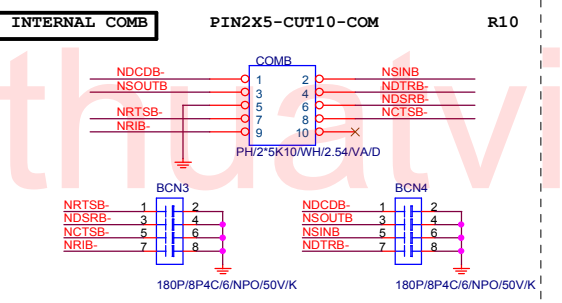

LPT PORT

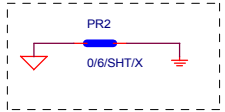
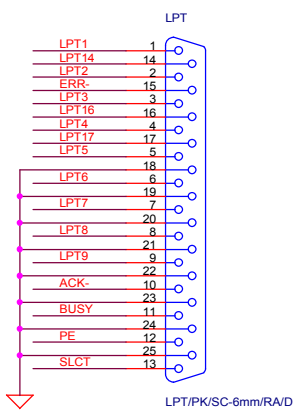
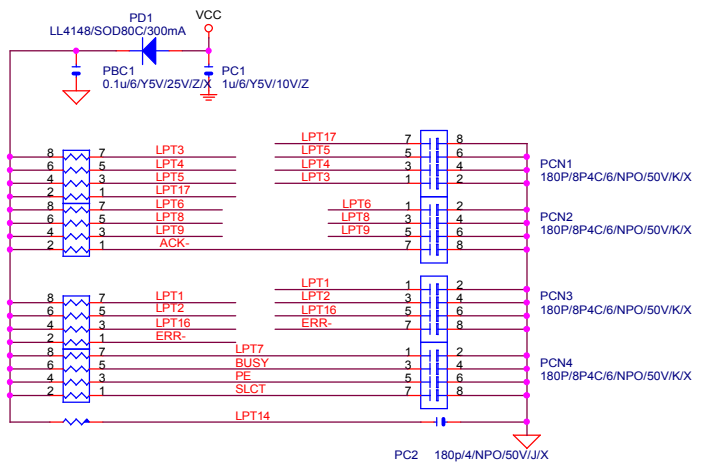
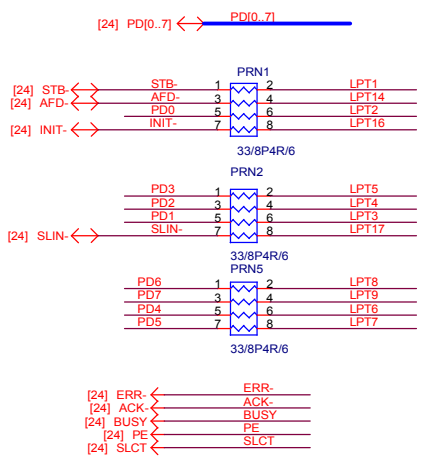

Gigabyte Technology		
COM & LPT PORT		
Title	Document Number	Rev
	945GM-DS2	2.0
Date:	Wednesday, November 08, 2006	Sheet 25 of 34

TEMP H/W MONITOR

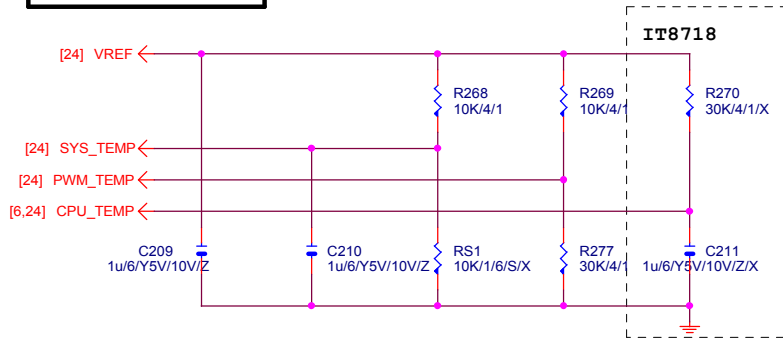

VOLTAGE-- H/W MONITOR

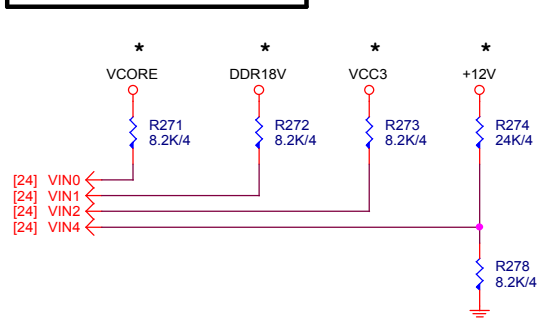

CASE OPEN

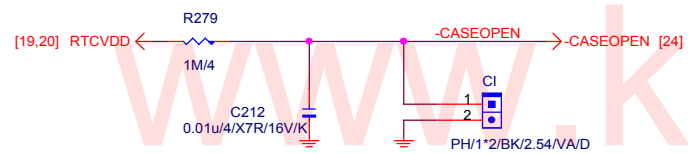

Case Open Circuits

DUAL BIOS

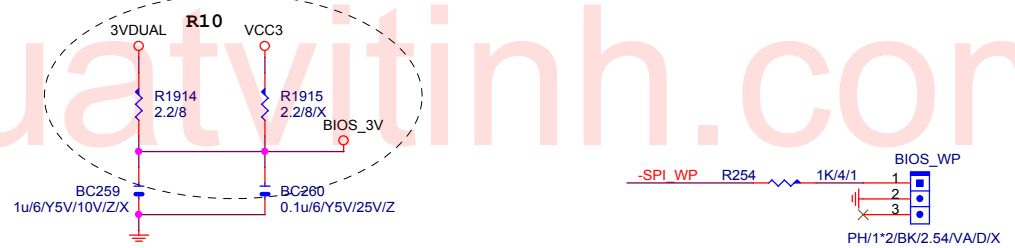

KB/MS

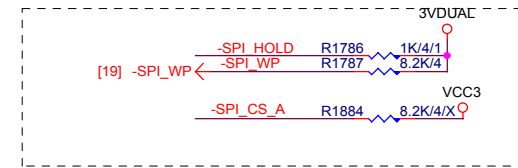
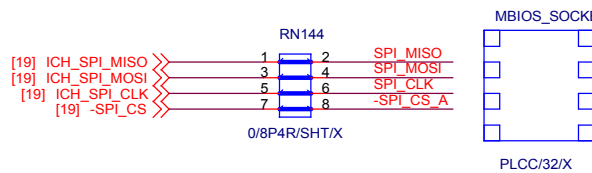
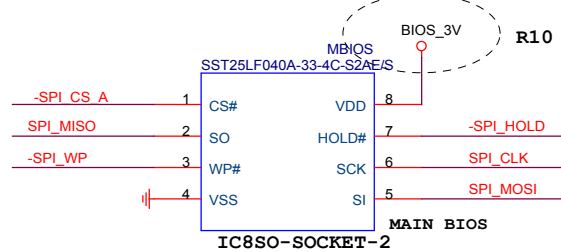
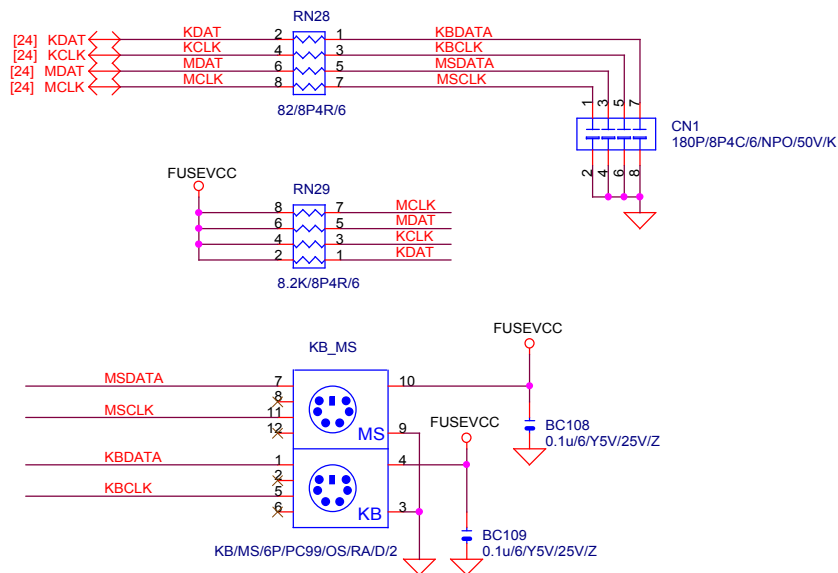

Gigabyte Technology

Title		
HW-MONITOR/CI/KB/MS/BIOS		
Size Custom	Document Number	Rev
	945GM-DS2	2.0
Date:	Wednesday, November 08, 2006	Sheet 26 of 34

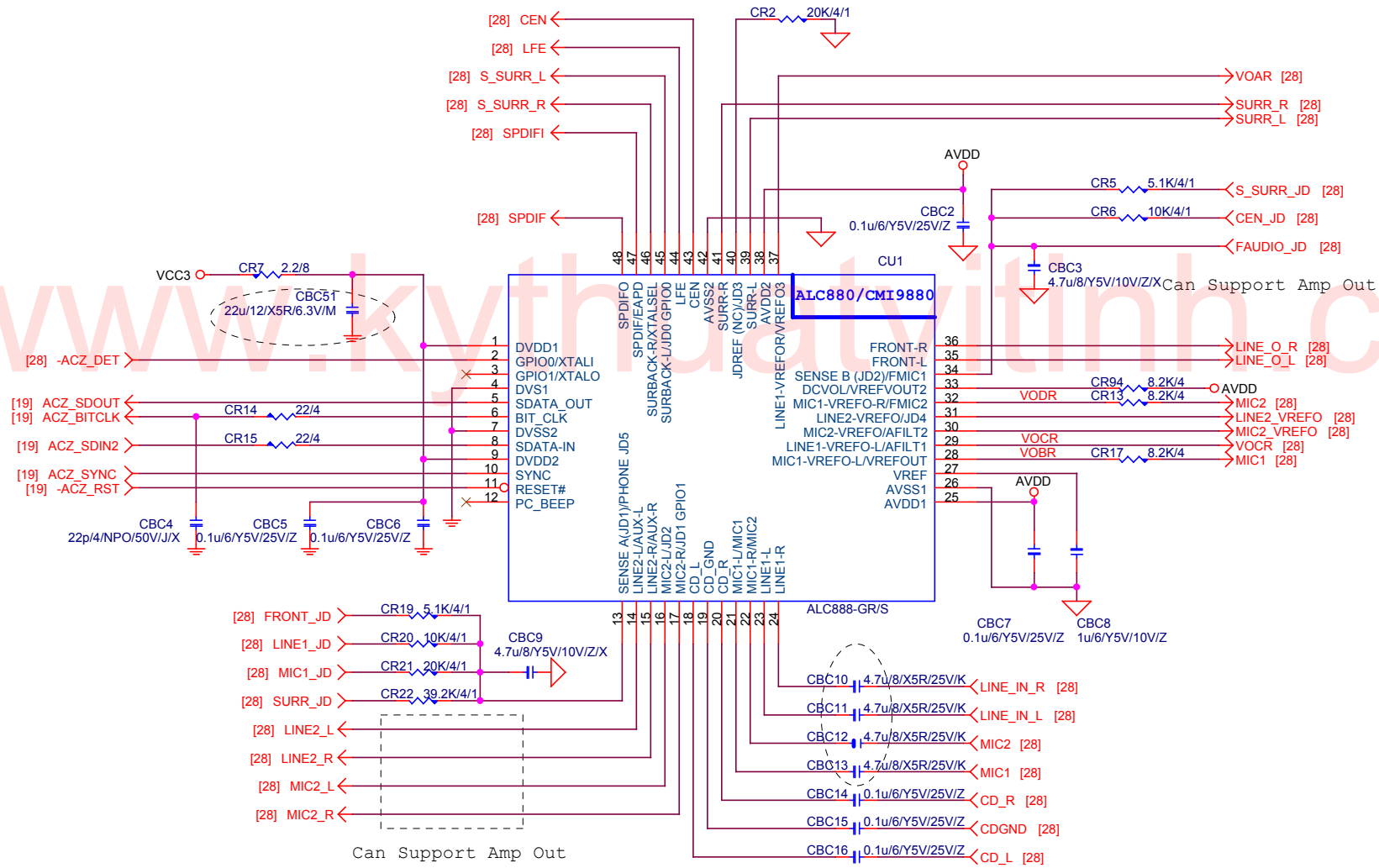

Gigabyte Technology

Title		
AZALIA ALC888		
Size Custom	Document Number	Rev
	945GM-DS2	2.0
Date:	Wednesday, November 08, 2006	Sheet 27 of 34

CODEC POWER/EMI PAD

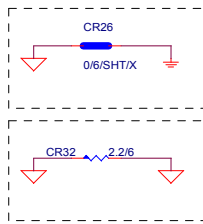
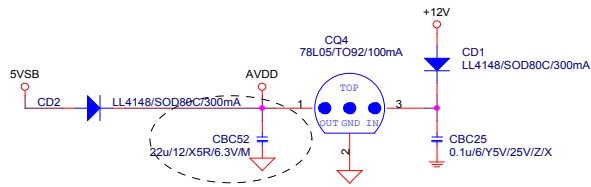

CD IN

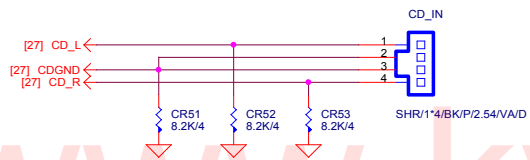

SPDIF

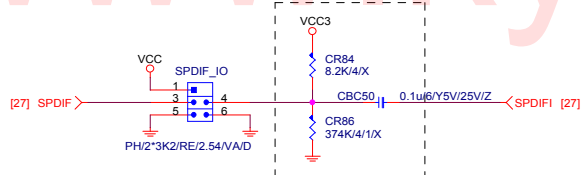

AZALIA JACK

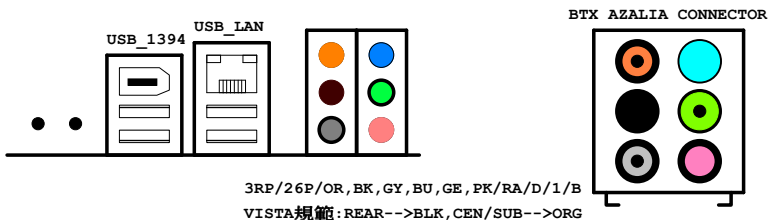

3RP/26P/OR, BK, GY, BU, GE, PK/RA/D/1/B
VISTA規範: REAR-->BLK, CEN/SUB-->ORG

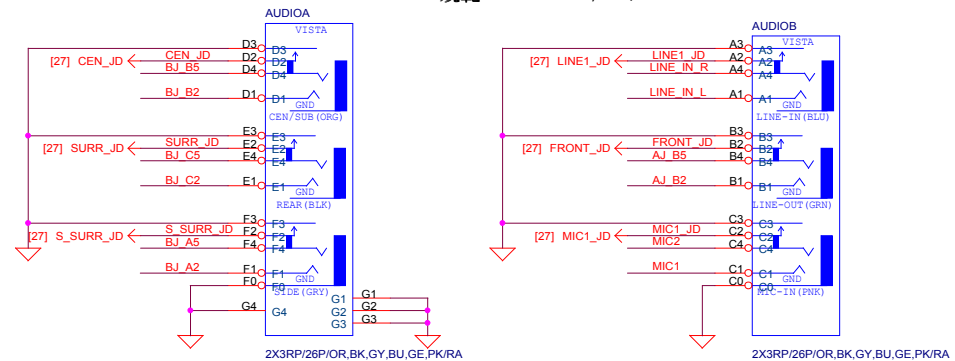

LINE-OUT

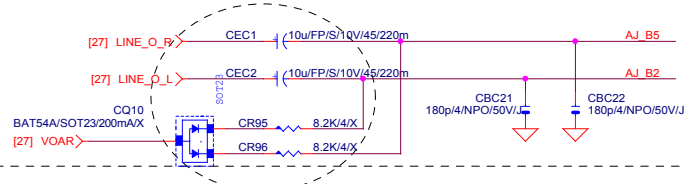

LINE-IN

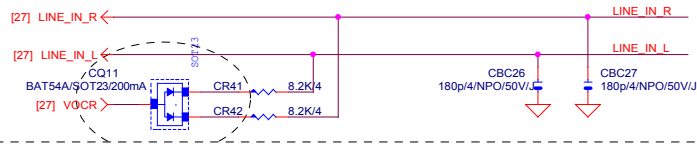

MIC-IN

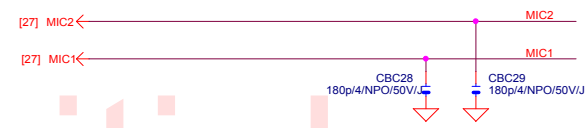

SURROUND

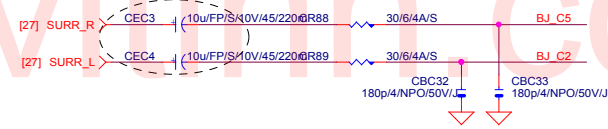

CEN/LFE

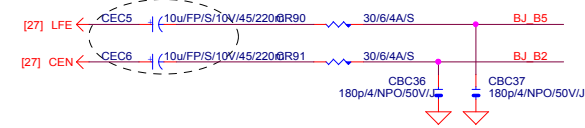

SURRBACK

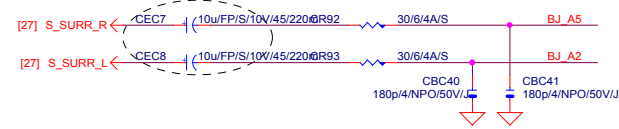

AZALIA FRONT PANEL

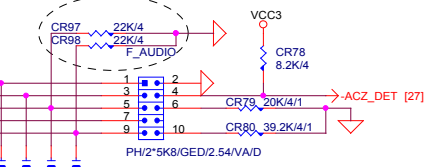
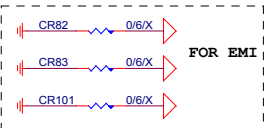
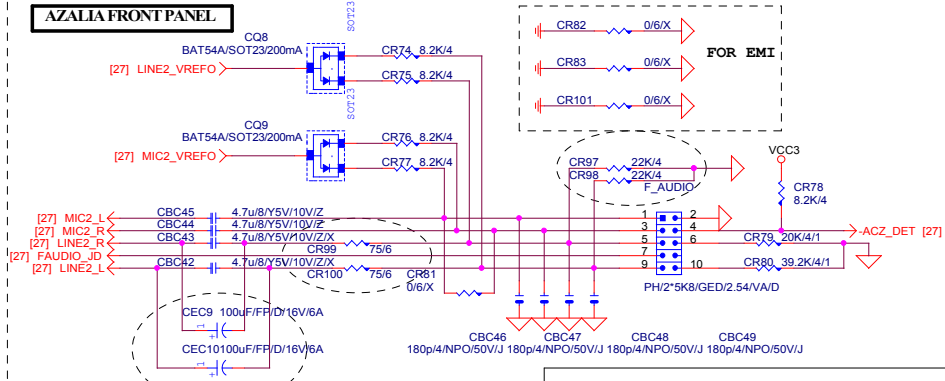

Gigabyte Technology			
AUDIO JACK			
Title	Document Number 945GM-DS2		
Size	Custom	Rev	2.0
Date:	Wednesday, November 08, 2006	Sheet	28 of 34

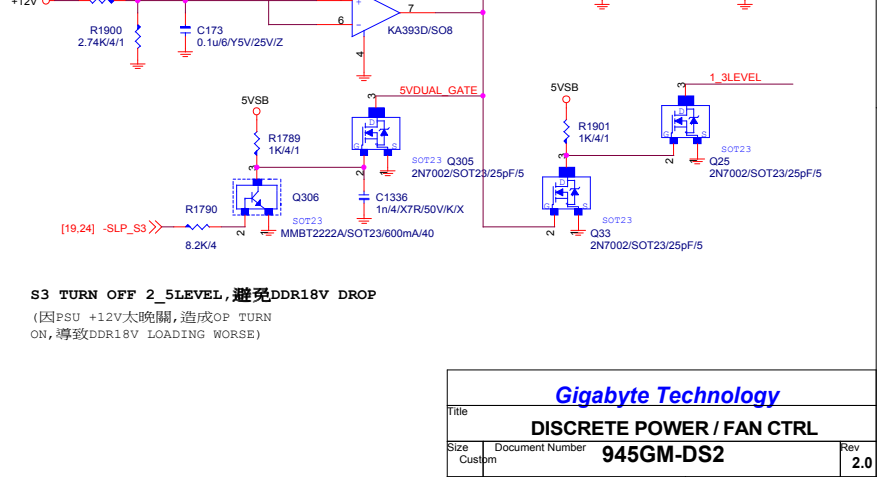
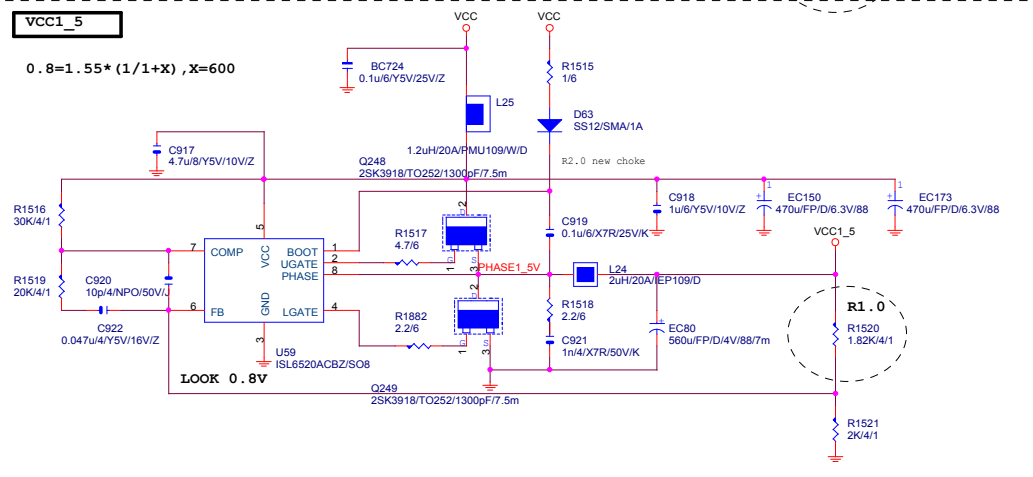
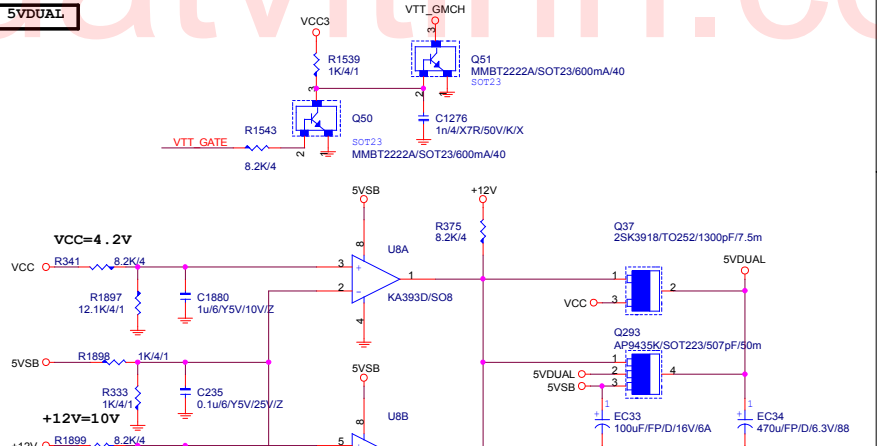
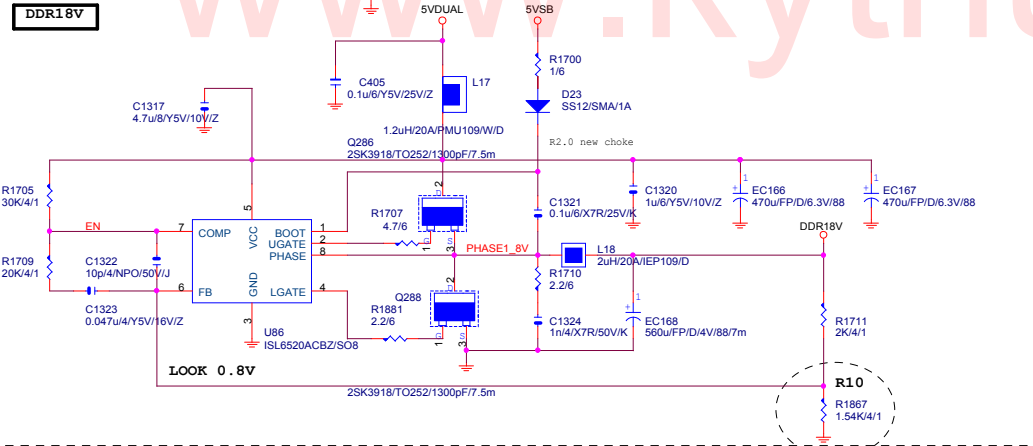
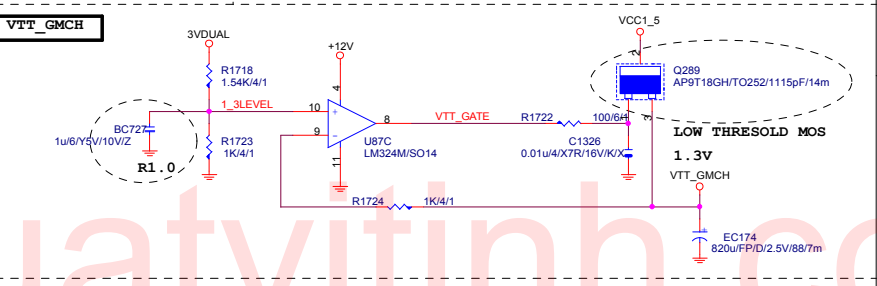
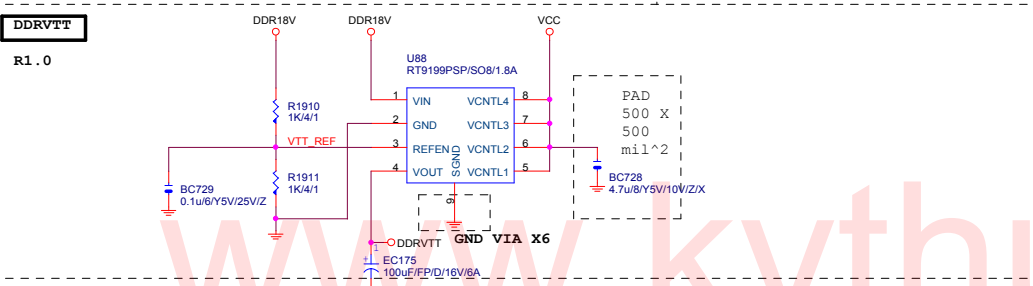
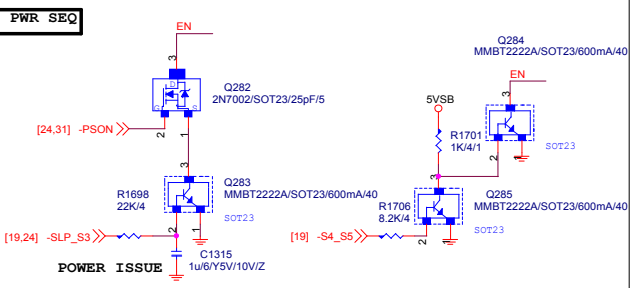
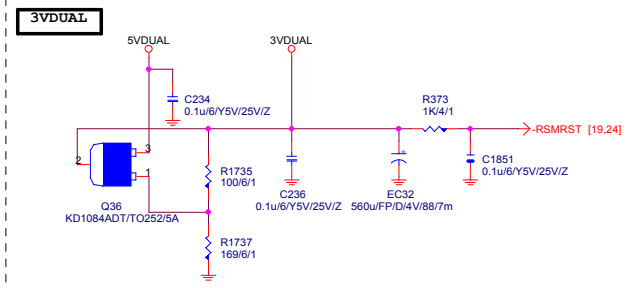
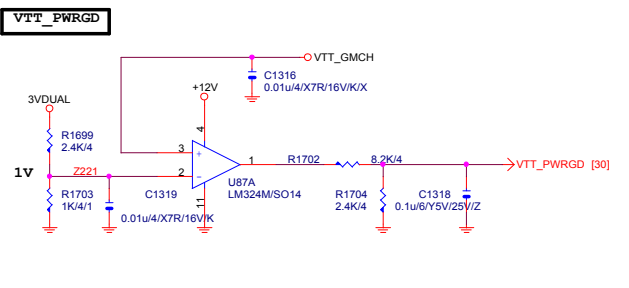

Gigabyte Technology			
DISCRETE POWER / FAN CTRL			
Size	Document Number	945GM-DS2	
Custom			
Date:	Wednesday, November 08, 2006	Sheet	29 of 34
Rev			2.0

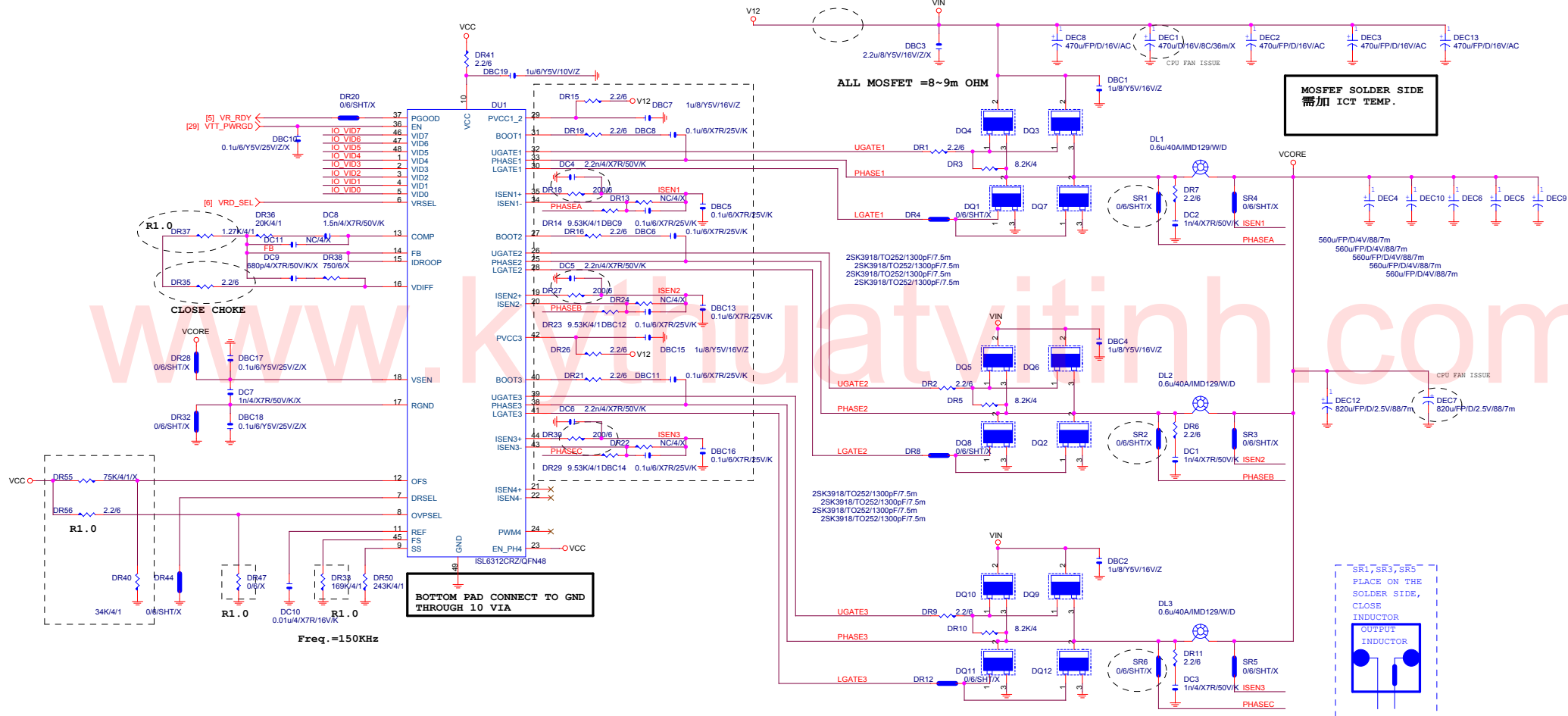

BOTTOM PAD CONNECT TO GND THROUGH 10 VIA

CLOSE CHOKE

**MOSFET SOLDER SIDE
需加 ICT TEMP.**

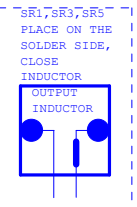

Freq. = 150kHz

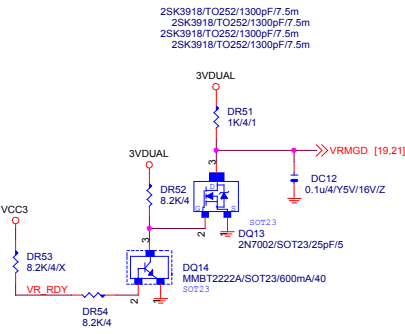
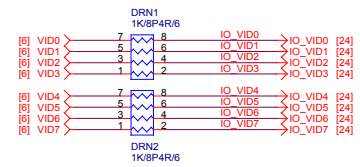

ATX POWER CONNECTOR

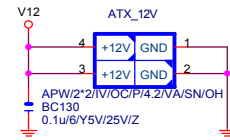
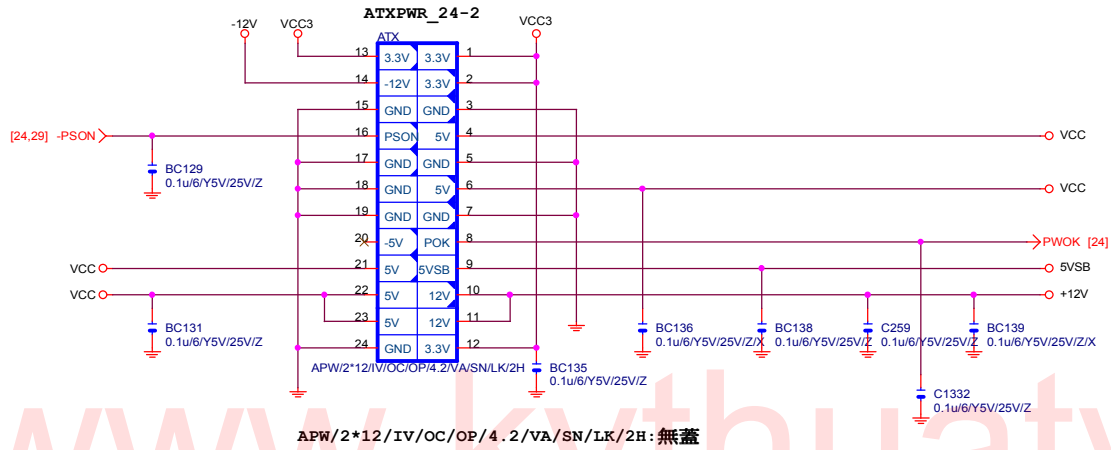

www.kythuatchinh.com

HOLE_3-RH-2

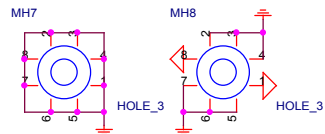
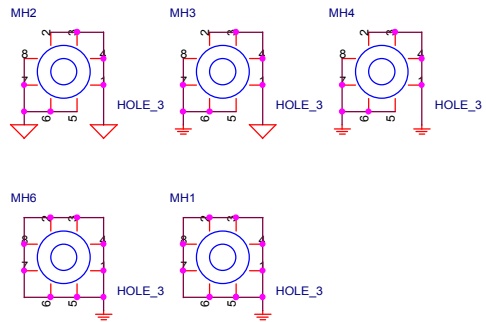

HOLE_3-RH-5MM

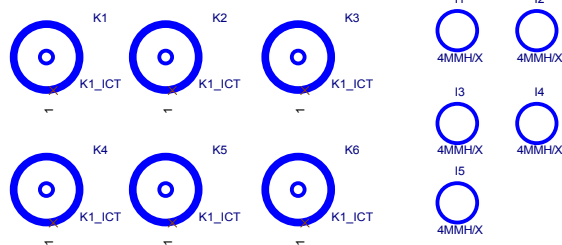

EMI ISSUE: BACKUP

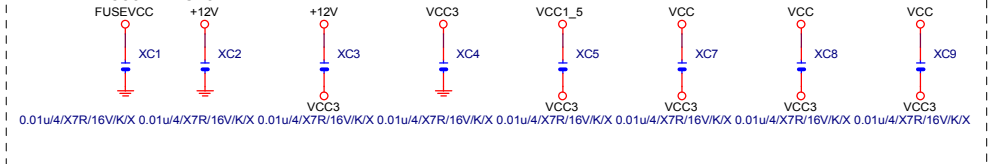

Gigabyte Technology		
ATX POWER CONNECTOR		
Size B	Document Number	Rev
	945GM-DS2	2.0
Date:	Wednesday, November 08, 2006	Sheet 31 of 34

CPU SMART FAN SMART FAN

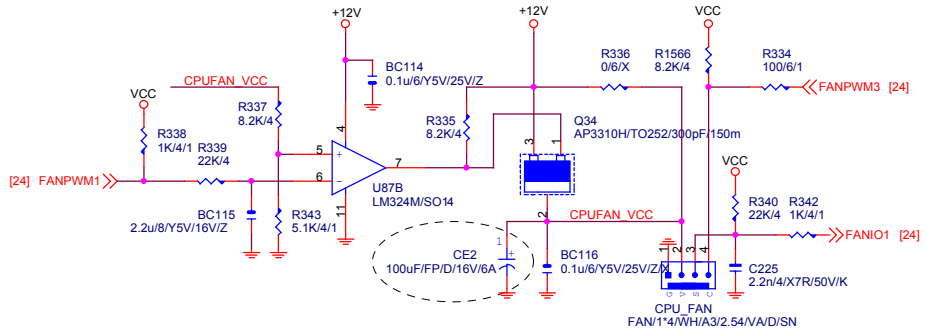

PROCESSOR HOT

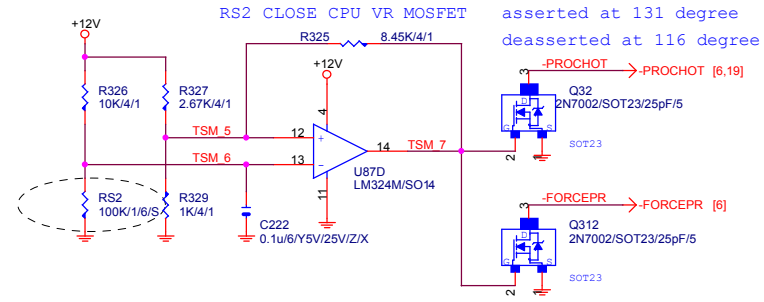

INTEL FRONT PANEL

MPD- : (GPIO25--VCCSUS3+HI+HI+DEFINED (C3/C4/S/1/S3/S/4/S5)) -->INTEL

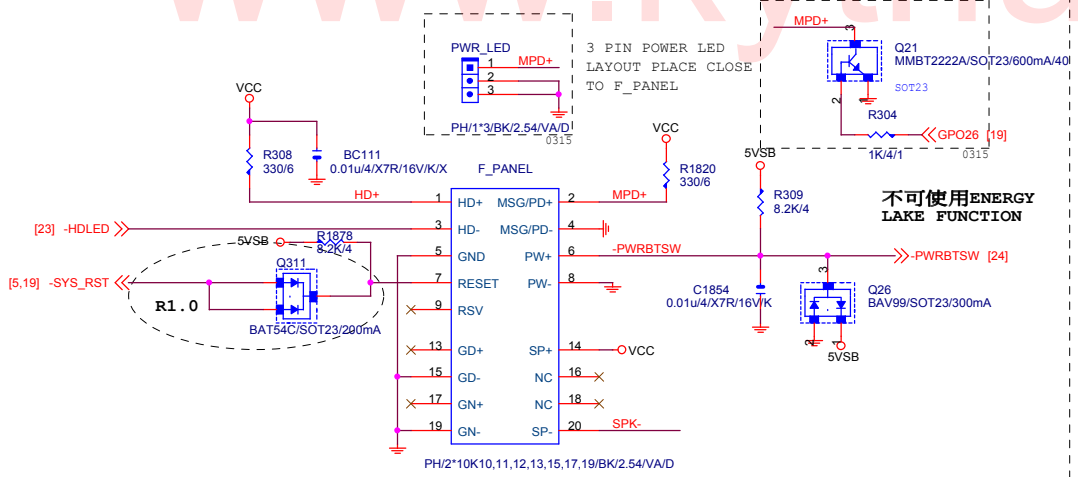

SYS_FAN

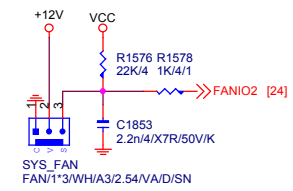

BUZZER

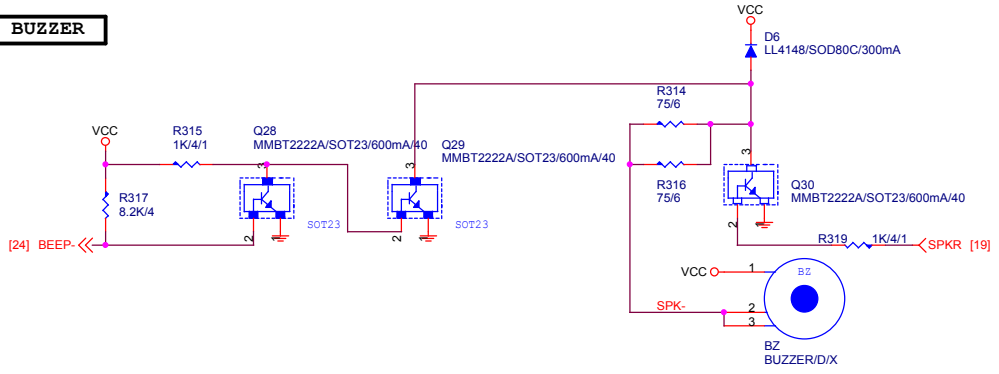

Gigabyte Technology		
FRONT PANEL		
945GM-DS2		Rev 2.0
Date:	Wednesday, November 08, 2006	Sheet 32 of 34

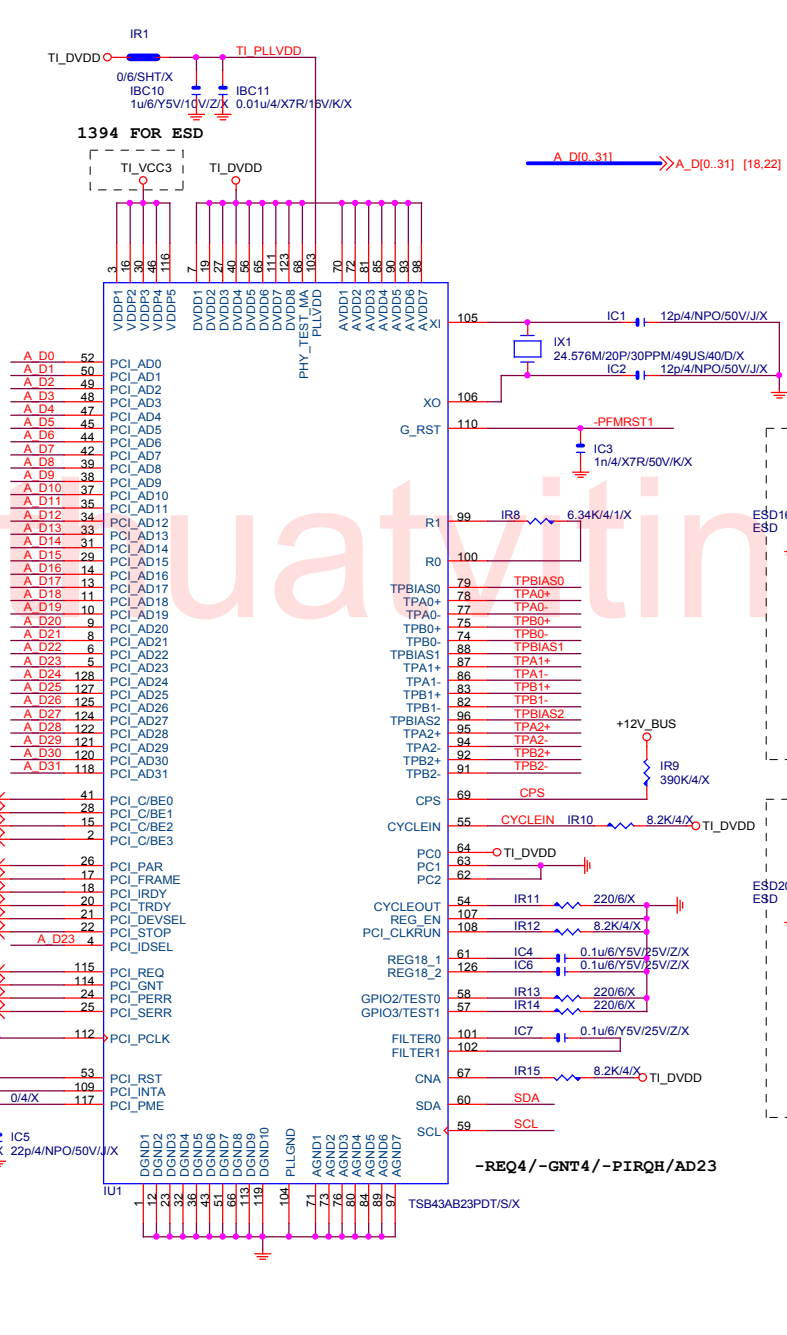
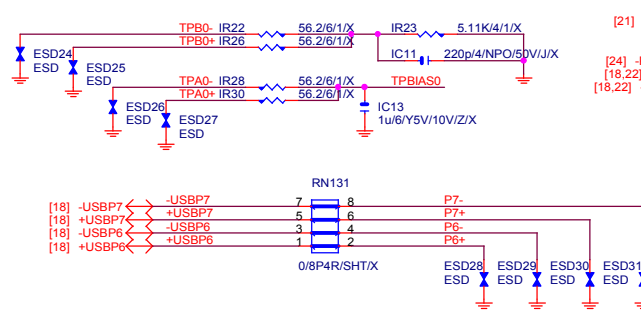
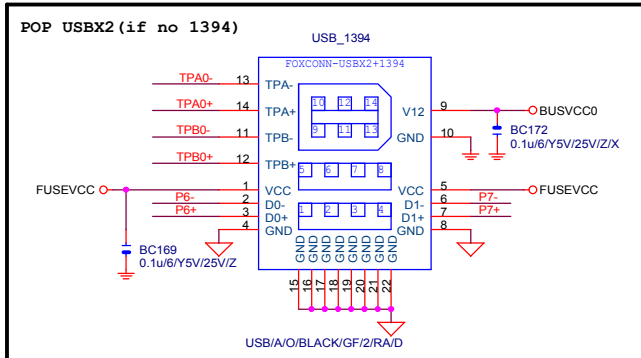
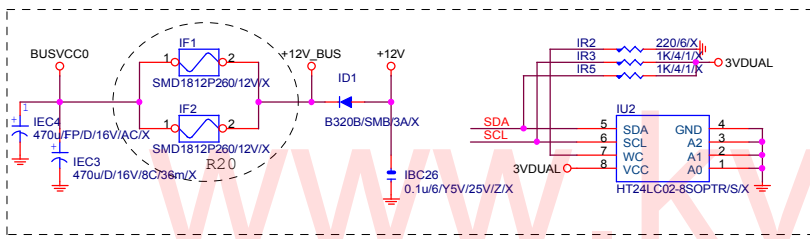
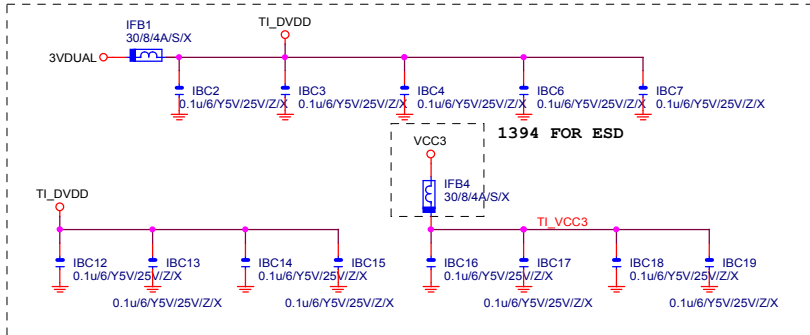

A D0	52	PCI_AD0	41	PCI_CBE0
A D1	50	PCI_AD1	28	PCI_CBE1
A D2	49	PCI_AD2	15	PCI_CBE2
A D3	48	PCI_AD3	2	PCI_CBE3
A D4	47	PCI_AD4	2	
A D5	45	PCI_AD5		
A D6	42	PCI_AD6		
A D7	42	PCI_AD7		
A D8	39	PCI_AD8		
A D9	38	PCI_AD9		
A D10	37	PCI_AD10		
A D11	35	PCI_AD11		
A D12	34	PCI_AD12		
A D13	33	PCI_AD13		
A D14	31	PCI_AD14		
A D15	29	PCI_AD15		
A D16	14	PCI_AD16		
A D17	13	PCI_AD17		
A D18	11	PCI_AD18		
A D19	10	PCI_AD19		
A D20	9	PCI_AD20		
A D21	8	PCI_AD21		
A D22	6	PCI_AD22		
A D23	5	PCI_AD23		
A D24	128	PCI_AD24		
A D25	127	PCI_AD25		
A D26	125	PCI_AD26		
A D27	124	PCI_AD27		
A D28	122	PCI_AD28		
A D29	121	PCI_AD29		
A D30	120	PCI_AD30		
A D31	118	PCI_AD31		
[18,22] -C_BE0	41	PCI_CBE0	115	PCI_REQ
[18,22] -C_BE1	28	PCI_CBE1	114	PCI_GNT
[18,22] -C_BE2	15	PCI_CBE2	24	PCI_PERR
[18,22] -C_BE3	2	PCI_CBE3	25	PCI_SERR
[18,22] PAR	17	PCI_FRAME	112	PCI_PCLK
[18,22] -FRAME	17	PCI_IRDY	53	PCI_RST
[18,22] -IRDY	18	PCI_TRDY	109	PCI_INTA
[18,22] -TRDY	20	PCI_DEVSEL	117	PCI_PME
[18,22] -DEVSEL	21	PCI_STOP		
[18,22] -STOP	22	PCI_IDSEL		
A D23	4			
[18,22] -REQ4	115			
[18] -GNT4	114			
[18,22] -PERR	24			
[18,22] -SERR	25			

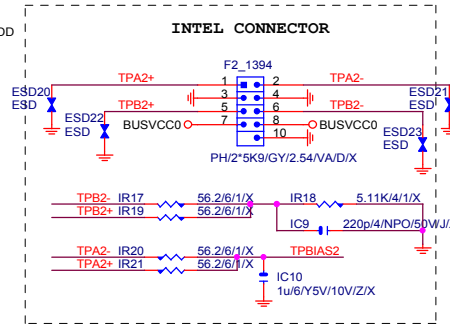
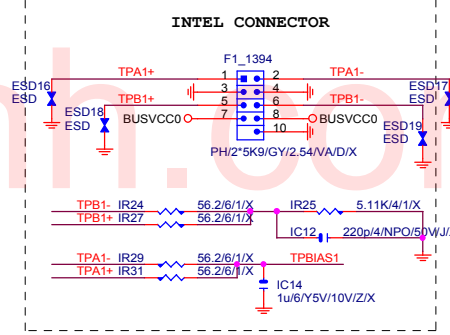

PCIe-1G LAN

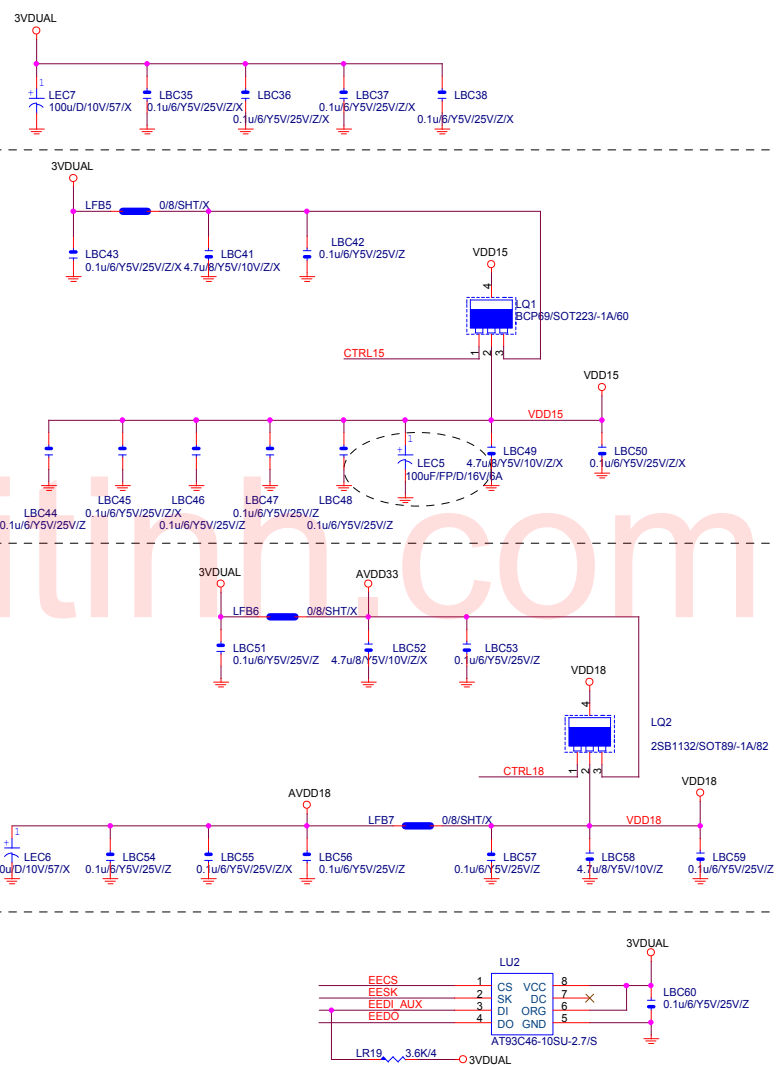
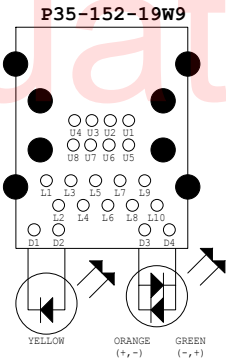
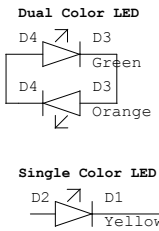
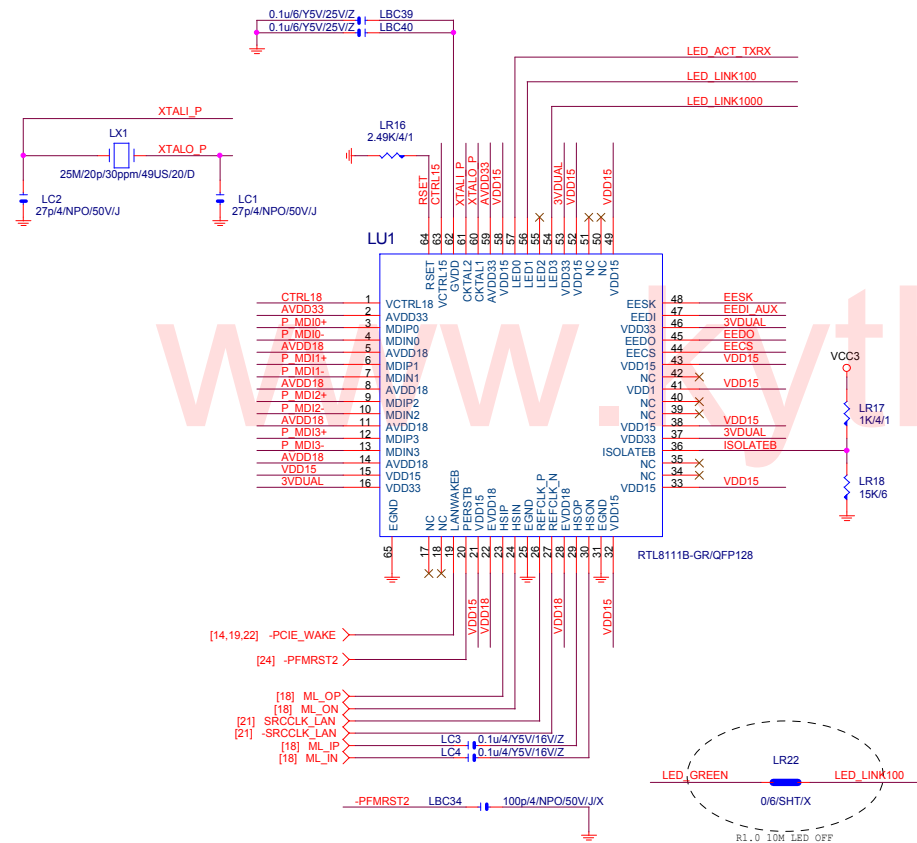

USB LAN CONNECTOR

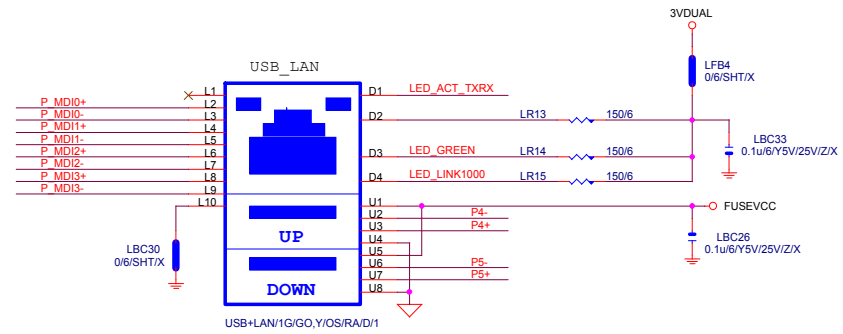

USB_LAN

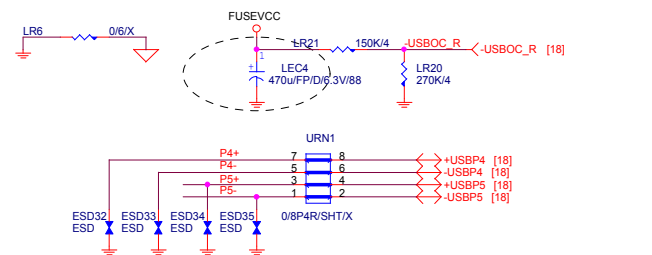

Gigabyte Technology			
REALTEK RTL8111B			
Title	Document Number	Rev	
	945GM-DS2	2.0	
Size Custom	Date: Wednesday, November 08, 2006	Sheet	34 of 34